

## Orion 180mm Maksutov-Cassegrain

#9969 Optical Tube Assembly



*Welcome to a new world of adventure!* Your new 180mm Maksutov-Cassegrain (Mak-Cass) telescope is a fine-quality instrument that excels for high-power observing and solar system imaging.

These instructions will help you set up and properly use and care for your telescope. Please read them over thoroughly before getting started.

### Getting Started

Your telescope comes fully assembled from the factory. The optics have been installed and collimated, so you should not have to make any adjustments to them. Keep the dust covers on the telescope when it is not in use.

Please keep the original shipping box. In the unlikely event you should need to ship the telescope back to Orion for warranty repair service, you should use the original packaging. The box also makes a very good container for storing the telescope.

The Orion 180mm Maksutov-Cassegrain has been upgraded to now include a 2" visual back with 1.25" adapter (**Figure 1**), allowing use of either 2" or 1.25" diagonals, eyepieces, and accessories (all sold separately). In addition, the 2" visual back can be removed to expose an SCT-threaded collar (2" x 24) TPI. This would accommodate SCT-specific accessories such as a thread-on diagonal or various camera adapters.

The 180mm Maksutov-Cassegrain comes equipped with a Vixen-style dovetail mounting plate for attachment of the optical tube to a compatible telescope mount. In addition, the optical tube is outfitted with a dovetail finder scope base, which accepts any Orion finder scope or reflex sight.



**Corporate Offices:** 89 Hangar Way, Watsonville CA 95076 - USA  
**Toll Free USA & Canada:** (800) 447-1001  
**International:** +1(831) 763-7000  
**Customer Support:** support@telescope.com

*Copyright © 2021 Orion Telescopes & Binoculars. All Rights Reserved. No part of this product instruction or any of its contents may be reproduced, copied, modified or adapted, without the prior written consent of Orion Telescopes & Binoculars.*

## Focusing

You will find the helical focus knob next to the visual back on the back end of the optical tube. Rotate the rubber-covered knob to change the focus. It operates by sliding the primary mirror inside the telescope incrementally forward or backward. Point the telescope so the front end is aimed in the general direction of an object you wish to view. When you first look in the eyepiece, the image you see may be fuzzy, or out of focus. If so, gently turn the focus knob with your fingers until the image becomes sharp. Go a little bit beyond sharp focus until the image just starts to blur again, then reverse the rotation of the knob, just to make sure you've hit the exact focus point. You will have to readjust the focus when aiming at subjects of varying distances, or after changing eyepieces.

If you have trouble focusing, rotate the focus knob counter-clockwise as far as it will go. Now look through the eyepiece while slowly rotating the focus knob clockwise. You should soon see the point at which focus is reached.

## Calculating Magnification

To calculate the magnification, or power, of a telescope with an eyepiece, simply divide the focal length of the telescope by the focal length of the eyepiece:

$$\frac{\text{Telescope Focal Length (mm)}}{\text{Eyepiece Focal Length (mm)}} = \text{Magnification}$$

For example, the 180mm Maksutov-Cassegrain, which has a focal length of 2700mm, used in combination with a 25mm eyepiece, yields a magnification of:

$$\frac{2700 \text{ mm}}{25 \text{ mm}} = 108x$$

It is desirable to have a range of eyepieces of different focal lengths to allow viewing over a range of magnifications. It is not uncommon for an observer to own five or more eyepieces. Orion offers many different eyepieces of varying focal lengths, so check the catalog or [www.OrionTelescopes.com](http://www.OrionTelescopes.com) for a wide selection of additional eyepieces to choose from.

Every telescope has a useful limit of power of about 2x per millimeter of aperture (i.e. 360x for the 180mm Mak-Cass). Claims of higher power by some telescope manufacturers are a misleading advertising gimmick and should be dismissed. Keep in mind that at higher powers, an image will always be dimmer and less sharp (this is a fundamental law of optics). The steadiness of the air (the "seeing") can also limit how much magnification an image can tolerate.

Always start viewing with your lowest-power (longest focal length) eyepiece in the telescope. It's best to begin observing with the lowest-power eyepiece, because it will typically provide the widest true field of view, which will make finding and centering objects much easier. After you have located and centered an object, you can try switching to a higher-power eyepiece to ferret out more detail, if atmospheric conditions permit. If the image you see is not crisp and steady, reduce the magnification by switching to a longer focal length eyepiece. As a general rule, a small but well-resolved image will show more detail and provide a more enjoyable view than a dim and fuzzy, over-magnified image.

## Photography

For photography with the 180mm Maksutov-Cassegrain, you can use a DSLR or any of a wide variety of astronomical CCD or CMOS cameras. For DSLRs you will need a T-ring for your particular camera as well as a camera adapter with a 2" nosepiece to couple the camera to the telescope. Larger astronomical cameras may already be equipped with a 2" nosepiece; if not you will need to purchase a 2" T-adapter. Smaller "planetary" cameras often have a 1.25" barrel, which

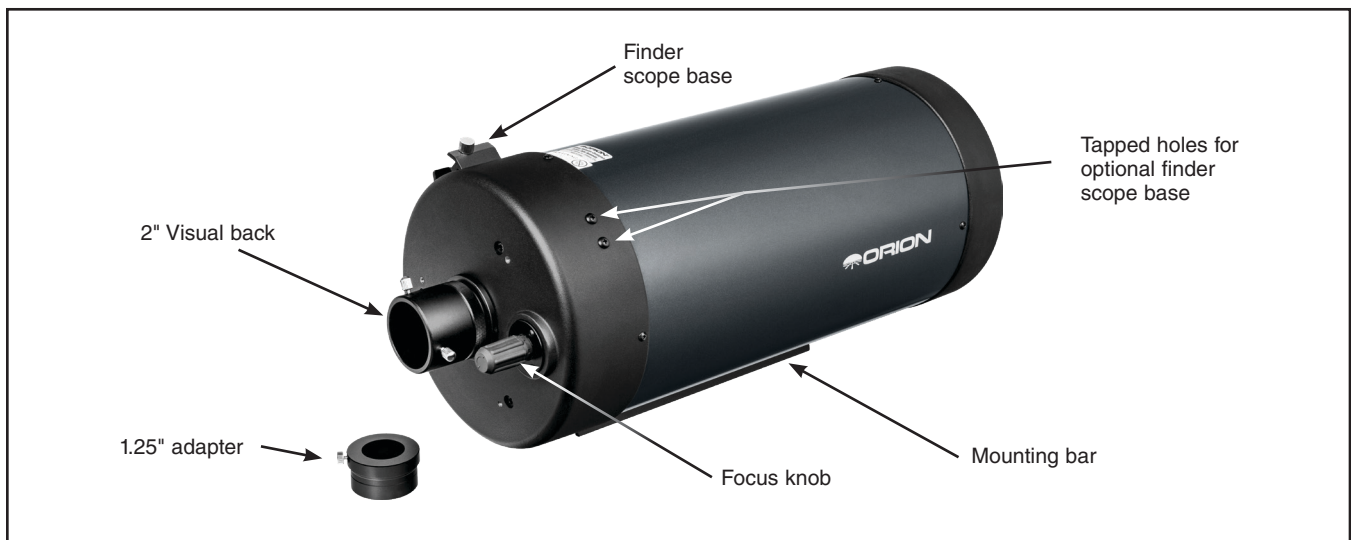

Figure 1. Key parts of the 180m Maksutov-Cassegrain.

you can insert directly into the 1.25" adapter that comes with the 180mm Maksutov-Cassegrain.

## Care & Maintenance

If you give your telescope reasonable care, it will last a lifetime. When not in use, keep the dust cover on the front of the tube and the dust cap on the eyepiece adapter. Store it in a clean, dry, dust-free place, safe from rapid changes in temperature and humidity. Do not store the telescope outdoors, although storage in a garage or shed is OK.

Your telescope requires very little mechanical maintenance. The optical tube is aluminum and has a smooth painted finish that is fairly scratch-resistant. If a scratch does appear on the tube, it will not harm the telescope. If you wish, you may apply some auto touch-up paint to the scratch. Smudges on the tube can be wiped off with a soft cloth and household cleaning fluid.

Any quality optical lens cleaning tissue and optical lens cleaning fluid specifically designed for multi-coated optics can be used to clean the front meniscus lens of the telescope. Never use regular glass cleaner or cleaning fluid designed for eyeglasses. Before cleaning with fluid and tissue, however, blow any loose particles off the lens with a blower bulb or compressed air. Then apply some cleaning fluid to a tissue, never directly on the optics. Wipe the lens gently, then remove any excess fluid with a fresh lens tissue. Oily fingerprints and smudges may be removed using this method. Use caution; rubbing too hard may scratch the lens. For the large surface of the meniscus lens, clean only a small area at a time, using a fresh lens tissue on each area. Never reuse tissues.

## Appendix: Collimation

Collimating is the process of aligning a telescope's optics. Your Maksutov-Cassegrain's primary mirror was aligned at the factory and should not need adjustment unless the telescope is handled roughly. This manual contains information on how to test the collimation of your telescope and instructions for proper alignment should that be needed.

### Star-Testing the Telescope

Before you start adjusting the primary mirror of your telescope, make certain that it is actually out of collimation by performing a star test.

**WARNING:** *Never look directly at the Sun through your telescope—even for an instant—without a professionally made solar filter that completely covers the front of the instrument, or permanent eye damage could result. Young children should use this telescope only with adult supervision.*

Take your telescope out at dusk and let it acclimate to the outside temperature; this usually takes 30-60 minutes. When it is dark, point the telescope upwards at a bright star and accurately center it in the eyepiece's field of view. Slowly de-focus the image with the focusing knob. If the telescope is correctly collimated, the expanding disk should be a circle (**Figure 2**). If the image is unsymmetrical, the scope is out of collimation. Also, the dark shadow cast by the secondary mirror should appear in the very center of the out-of-focus circle, like the hole in a donut. If the "hole" appears off-center, the telescope is out of collimation.

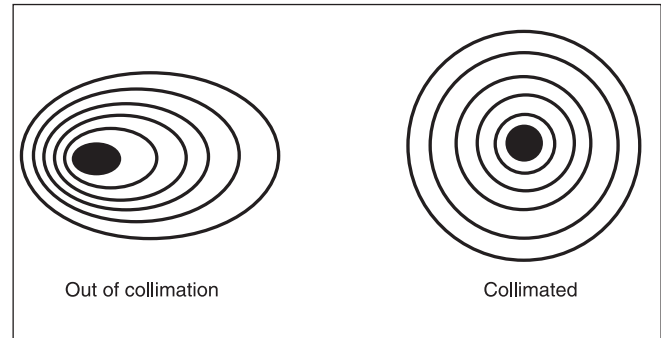

**Figure 2.** A star test will determine if a telescope's optics are properly collimated. An unfocused view of a bright star through the eyepiece should appear as illustrated on right if optics are perfectly collimated. If circle is unsymmetrical, as in illustration on left, scope needs collimation.

If you try the star test but the bright star you have selected is not accurately centered in the eyepiece, the optics will always appear out of collimation, even though they may be perfectly aligned. It is critical to keep the star centered, so over time you will need to make slight corrections to the telescope's position in order to account for the sky's apparent motion.

### Collimating

To collimate your telescope, remove the diagonal and eyepiece and look into the rear opening of the tube (also remove the dust cover from the front of the tube). This should be done indoors, with the telescope pointed at a white wall in a well-lit room. Try to keep your eye centered with respect to the rear opening of the tube as best as possible. Using an Orion Collimating Eyepiece will aid greatly in keeping your eye centered and is strongly recommended.

Alternatively, you can make a crude collimating tool out of an empty, black plastic 35mm film canister. It will not have crosshairs, so it won't be as precise, but it will be better than nothing. Cut 1/2" from the top lip of the canister and put a 1/16" to 1/8" diameter hole in the center of the canister's bottom surface. Insert the film canister collimating tool into the focuser like you would an eyepiece with the bottom surface outward.

Once you are ready to collimate, look into the rear opening of the tube. If your telescope is out of collimation, it will resemble **Figure 3a**. You will see a reflection of the inside of the optical tube resembling a black crescent. A properly collimated scope will resemble **Figure 3b**. The direction of misalignment in

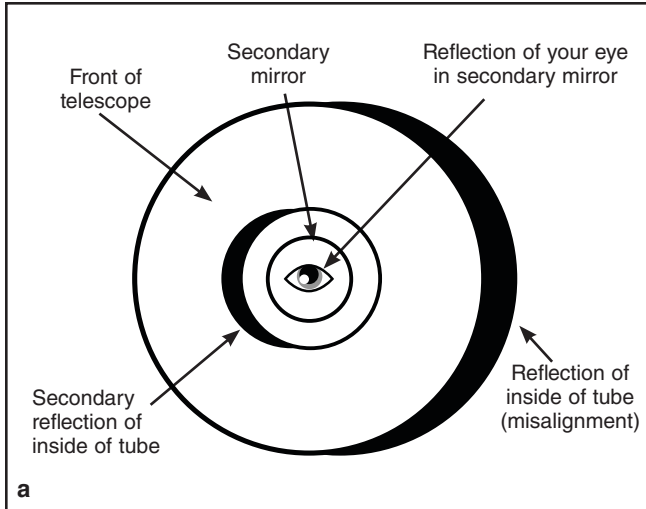

**Figure 3. a)** If the telescope's optics are out of alignment the view through rear opening of the telescope will resemble this.

your telescope may differ from **Figure 3a**, but the diagram will give you a general idea of how things will look.

Note there are three pairs of collimation screws on the back of the optical tube (**Figure 4**). The tilt of the primary mirror is adjusted with the three pairs of collimation screws. You will need a 4mm and 2.5mm hex key to turn these screws.

Each pair of collimation screws work together to adjust the tilt of the primary mirror. One screw pushes the mirror cell forward, while the other screw pulls the mirror cell back. One must be loosened and the other tightened by equal amounts in order to adjust the tilt. Look into the rear opening of the tube and locate the black crescent that indicates the optics are out of collimation. Note which way the front of the telescope would need to move in order to "fill" that black crescent and resemble **Figure 3b**. Then look at the back end of the telescope and locate the pair of collimation screws that are in the direction that the front of the telescope needs to move. Tighten one of these screws by one turn, and loosen the other screw of the pair by one turn. Look into the rear opening of the tube and determine if the black crescent has reduced in size, increased in size, or been "filled." If the crescent has reduced in size, continue adjusting the pair of collimation screws in the same manner until the crescent has been completely "filled." If the crescent has increased in size, the optics have been moved further out of alignment. To correct this, loosen and tighten the same pair of collimation screws by one turn to undo the previous adjustment. Then adjust the other two pairs of collimation screws until the black crescent is "filled."

It will take a little trial and error to get a feel for how to tilt the mirror using the collimation screw pairs. Again, collimation should only be attempted if you have confirmed the telescope is actually out of collimation by performing a star test.

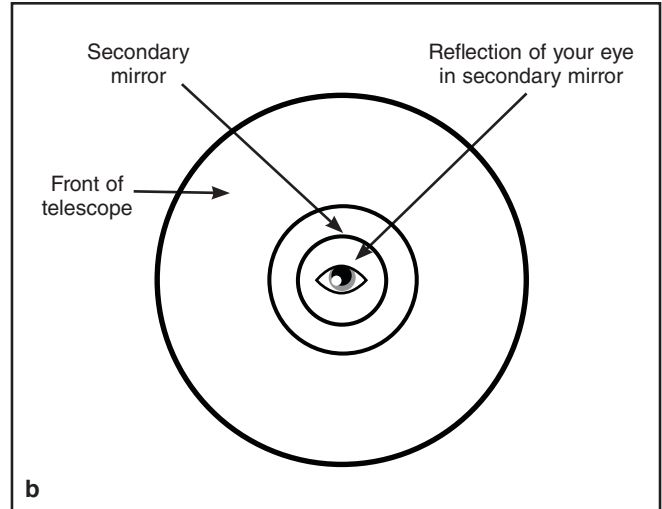

**b)** With the optics properly aligned the view through the rear opening of the telescope will resemble this.

### Finishing Collimation

Once you have finished adjusting your telescope, you will need to perform another star test (described earlier) to check the collimation. If your telescope appears collimated after star testing, it should not need adjustment again unless it is roughly handled.

If you have gone through this process and your telescope is still out of collimation, please contact Orion customer support. You may need to return the telescope for repair (covered on warranty for 1 year after purchase).

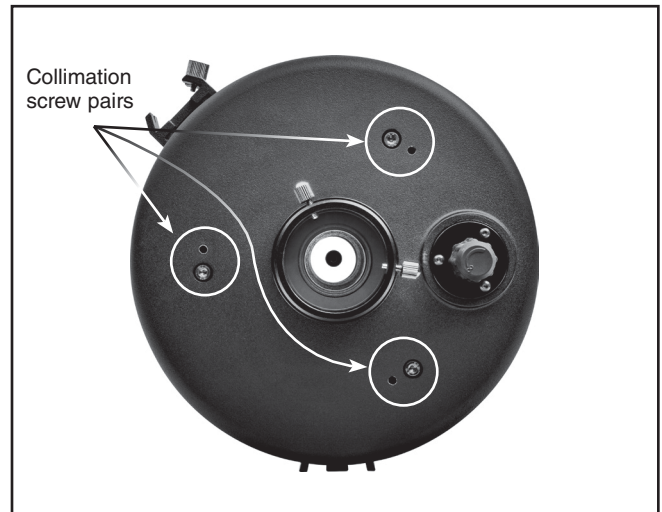

**Figure 4.** The 180mm Maksutov-Cassegrain collimation screws

---

## Specifications

Optical design:	Maksutov-Cassegrain
Aperture: 180mm	
Effective focal length:	2700mm
Focal ratio:	f/15.0
Central obstruction diameter:	41mm
Primary mirror coating:	Aluminum with SiO <sub>2</sub> overcoat
Meniscus lens coating: both sides of lens	Anti-reflection multi-coatings on
Visual back:	2" with 1.25" adapter
Mounting plate:	Vixen style dovetail bar
Weight:	16 lbs.

---

## One-Year Limited Warranty

This Orion product is warranted against defects in materials or workmanship for a period of one year from the date of purchase. This warranty is for the benefit of the original retail purchaser only. During this warranty period Orion Telescopes & Binoculars will repair or replace, at Orion's option, any warranted instrument that proves to be defective, provided it is returned postage paid. Proof of purchase (such as a copy of the original receipt) is required. This warranty is only valid in the country of purchase.

This warranty does not apply if, in Orion's judgment, the instrument has been abused, mishandled, or modified, nor does it apply to normal wear and tear. This warranty gives you specific legal rights. It is not intended to remove or restrict your other legal rights under applicable local consumer law; your state or national statutory consumer rights governing the sale of consumer goods remain fully applicable.

For further warranty information, please visit [www.OrionTelescopes.com/warranty](http://www.OrionTelescopes.com/warranty).



**Corporate Offices:** 89 Hangar Way, Watsonville CA 95076 - USA  
**Toll Free USA & Canada:** (800) 447-1001  
**International:** +1(831) 763-7000  
**Customer Support:** [support@telescope.com](mailto:support@telescope.com)

*Copyright © 2021 Orion Telescopes & Binoculars. All Rights Reserved. No part of this product instruction or any of its contents may be reproduced, copied, modified or adapted, without the prior written consent of Orion Telescopes & Binoculars.*