

# INSTRUCTION MANUAL

## Orion® Pro Pluck-Foam Waterproof Accessory Cases

#15958 / #15959

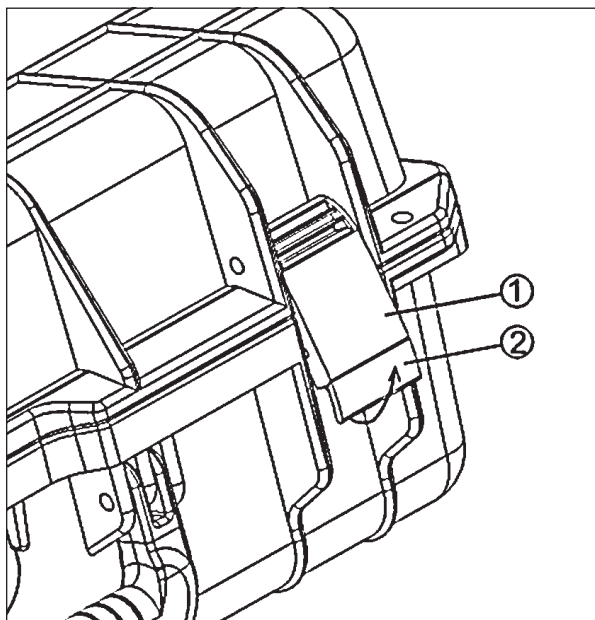

### Directions for Use

The latching device has two features: The large portion which is the latch itself (1), and the small latch release tab (2) at the bottom of the latch.

- To close, lower the latch (1) and press until it snaps.
- To open, pull up the latch release tab (2)
- Never press the latch release tab (2) to close the latch as damage may result.

### Case Features

- Water proof – Sealed for protection against moisture and dust
- Pressure release valve – aids in opening case after changing pressure
- Rust proof – made of durable, high impact polypropylene
- Shock/Vibration proof – Includes two pieces pre-cut foam and two pieces wave foam
- Floats on water
- Includes Strap and pre-drilled holes for lock



Open



Close

### One-Year Limited Warranty

This Orion product is warranted against defects in materials or workmanship for a period of one year from the date of purchase. This warranty is for the benefit of the original retail purchaser only. During this warranty period Orion Telescopes & Binoculars will repair or replace, at Orion's option, any warranted instrument that proves to be defective, provided it is returned postage paid. Proof of purchase (such as a copy of the original receipt) is required. This warranty is only valid in the country of purchase.

This warranty does not apply if, in Orion's judgment, the instrument has been abused, mishandled, or modified, nor does it apply to normal wear and tear. This warranty gives you specific legal rights. It is not intended to remove or restrict your other legal rights under applicable local consumer law; your state or national statutory consumer rights governing the sale of consumer goods remain fully applicable.

For further warranty information, please visit [www.OrionTelescopes.com/warranty](http://www.OrionTelescopes.com/warranty).

 **ORION®**  
TELESCOPES & BINOCULARS

Providing Exceptional Consumer Optical Products Since 1975

Customer Support:

[www.OrionTelescopes.com/contactus](http://www.OrionTelescopes.com/contactus)

Corporate Offices:

89 Hangar Way, Watsonville CA 95076 - USA

© Copyright 2013 Orion Telescopes & Binoculars