

## INSTRUCTION MANUAL

# Orion® EON™ 115mm and 130mm ED Triplet Apochromatic Refractors

#10087 EON 115

#9565 EON 130



 **ORION**  
TELESCOPES & BINOCULARS

*Providing Exceptional Consumer Optical Products Since 1975*

*Customer Support:*

[www.OrionTelescopes.com/contactus](http://www.OrionTelescopes.com/contactus)

*Corporate Offices:*

89 Hangar Way, Watsonville CA 95076 - USA

Copyright © 2015 Orion Telescopes & Binoculars

All Rights Reserved. No part of this product instruction or any of its contents may be reproduced, copied, modified or adapted, without the prior written consent of Orion Telescopes & Binoculars.

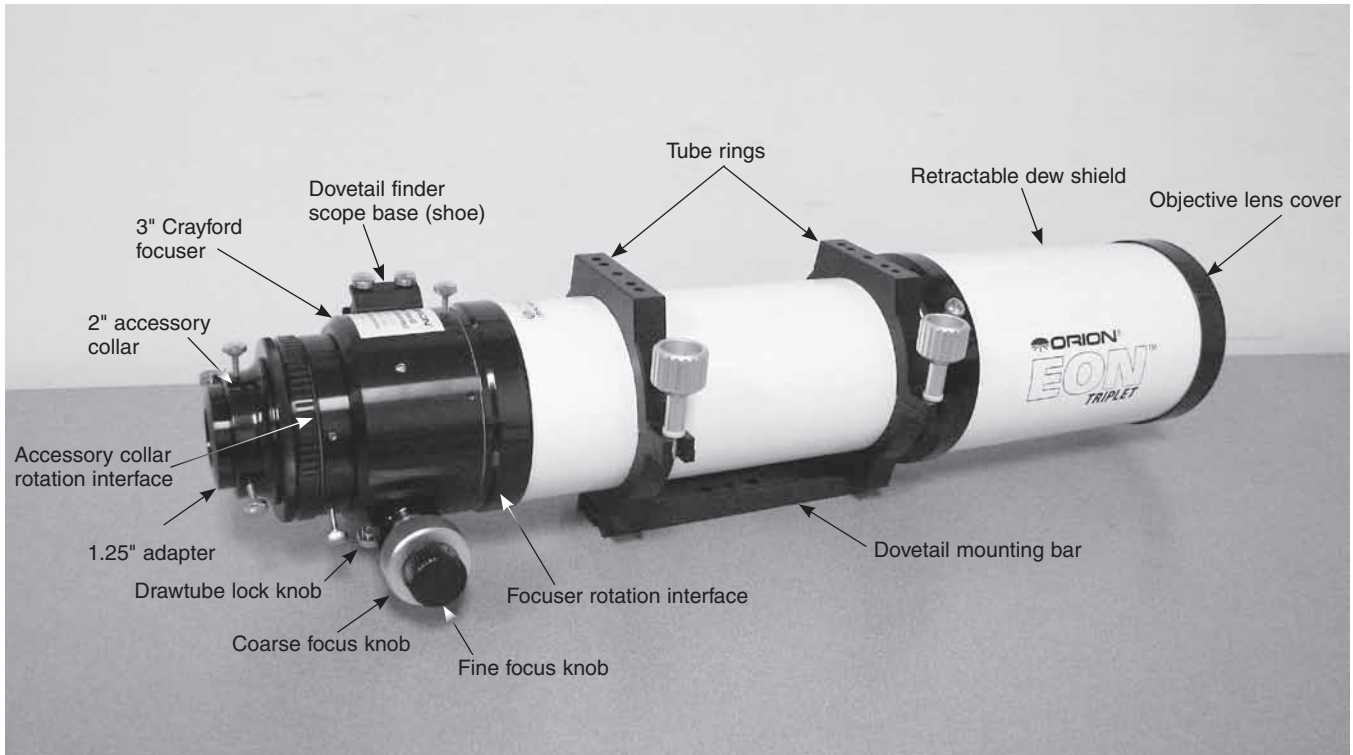

**Figure 1.** Features and components of the EON Triplet apochromatic refractor

## Contents

1. Parts List . . . . .	2
2. Getting Started . . . . .	2
3. Features and Functions . . . . .	2
4. Operating the EON f/7 Triplet . . . . .	4
5. Care & Maintenance . . . . .	5
6. Specifications . . . . .	6

*Congratulations on your purchase of an Orion EON f/7 ED Triplet Apochromatic Refractor! The EON 115mm and 130mm ED Triplet apo's have been designed with high-quality, precision ED optics and superior mechanical construction, making them ideally suited to both high-performance imaging or visual stargazing pursuits. These instructions will familiarize you with the features of your instrument and how to use it.*

**WARNING:** Do NOT look at the Sun without a professionally made solar filter on the telescope; serious eye damage may result if you look at the Sun with any unfiltered optical instrument. Do not leave the telescope unsupervised around children. Always cover the lenses when leaving the telescope in direct sunlight.

## 1. Parts List

- EON f/7.0 ED Triplet optical tube assembly
- Aluminum objective cap
- 1.25" eyepiece adapter
- Tube rings (pair)
- Dovetail mounting bar
- Hard case

## 2. Getting Started

The EON 115mm and 130mm ED Triplet apochromatic refractors come ready for use from the factory. Your telescope's optics have been assembled and precisely collimated at the factory, so they should not require any adjustments. Please keep the original shipping box. In the unlikely event that you need to ship the telescope back to Orion for warranty repair service, you should use the original packaging.

## 3. Features and Functions

The EON f/7 Triplet has premium features designed to maximize the performance of the scope and its convenience of use. Please refer to **Figure 1** to become familiar with the telescope's features.

### Retractable Dew Shield

The dew shield of the EON 115mm and 130mm is retractable, allowing the telescope to become more compact for storage. To extend the dew shield, loosen the thumbscrew at the base of the dew shield and simply pull it forward until it stops. Then lightly retighten the thumbscrew.

### 3" Dual-Speed Crayford Focuser

Focusing the EON is truly a joy, thanks to the all-machined, extra-large 3" Crayford focuser (**Figure 2**). It provides exceptionally smooth, backlash-free focus motion and excellent rigidity for holding heavy imaging trains without flexure or slippage. The 3"-diameter drawtube ensures that even full-frame imaging sensors will have a generously large fully illuminated field. A drawtube lock knob is located on the underside of the focuser (**Figure 2B**).

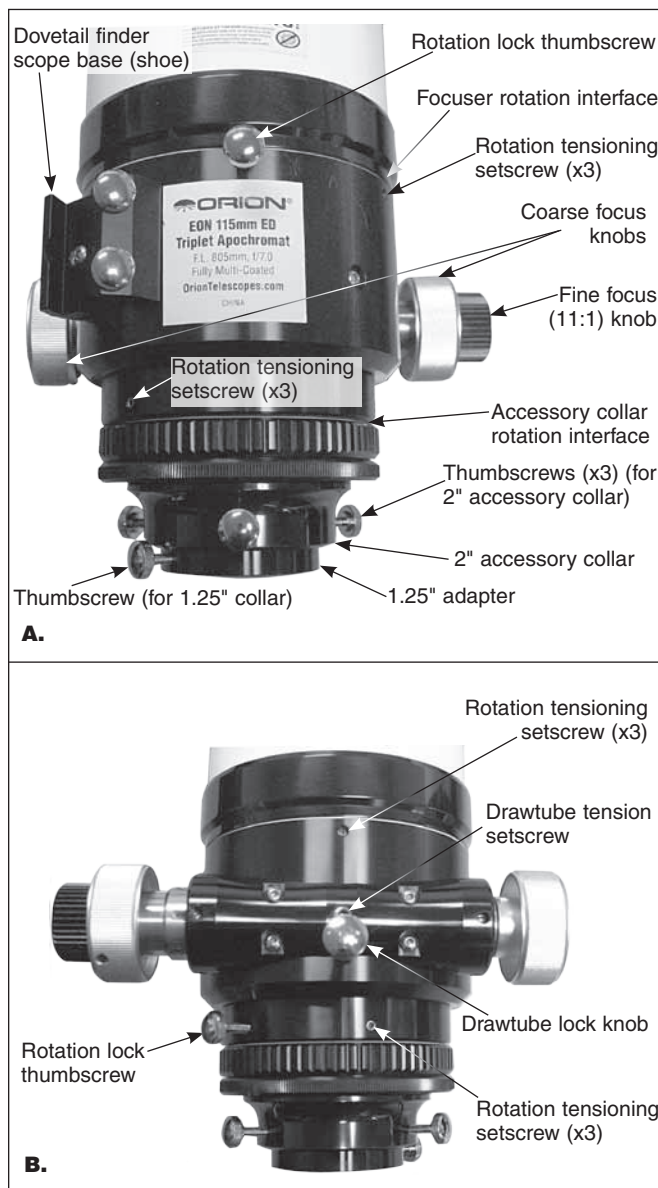

**Figure 2.** The 3" dual-speed Crayford focuser used on both the EON 115 and 130 **A)** Top side, **B)** bottom side

The dual-speed (11:1) focusing mechanism will keep your target object crisp and sharp. For quick focusing, the two large focus knobs provide a coarse focus. For more precise focusing, as needed for applications such as high-power planetary observing and imaging with a CCD or digital camera, the smaller focus knob on the right side (**Figure 2A**) offers an 11:1 fine focus adjustment (~11 turns of the fine focus knob equal 1 turn of the coarse focus knob).

If you find that the focus motion feels too stiff or if, on the contrary, the drawtube slips easily under the weight of your eyepiece or camera, you can make adjustments to the focuser tension with the focuser tension setscrew located on the bottom side of the focuser (**Figure 2B**). Use a 4mm hex key to tighten or loosen this setscrew until the focuser motion feels smooth and the drawtube holds in place under load when you have obtained focus. It may be necessary to make adjustments when the weight of your accessories changes significantly.

### Engraved Millimeter Scale on Focuser Drawtube

The drawtube of the EON's focuser features a laser-engraved millimeter scale on top, which aids in providing repeatable focus. When precise focus is achieved, noting the value on the scale where the drawtube meets the focuser housing will allow you to return to approximately the same point, such as when focusing the same camera in subsequent imaging sessions. Using the scale can save time compared to finding the focusing point "from scratch."

### Focuser Rotation

The focuser on the EON 115mm and 130mm has two rotatable components. The entire focuser can be rotated just behind the tapered collar where the focuser attaches to the optical tube (see **Figure 2A**). The second point of rotation is the 2" accessory collar behind the focus knobs. Both of the rotation mechanisms have three recessed setscrews that must be slightly loosened to permit rotation, as well as a thumbscrew lock.

Why two points of rotation? Rotating the entire focuser will reorient the focus knobs to a position that may be more desirable, depending on your mount setup and what you're observing or imaging. For instance, this feature can allow you to keep the focus knobs parallel to the ground no matter how your telescope is positioned. Rotating the 2" accessory collar, additionally, may be useful for framing a target object on your camera sensor for imaging.

To rotate the focuser, loosen the rotation lock thumbscrew (**Figure 2B**) a turn or so counterclockwise. Gently rotate the focuser to the desired orientation, then lock it in place by turning the lock thumbscrew clockwise. If you find the focuser is difficult to rotate, you may have to very slightly loosen the three rotation tensing setscrews around the focuser with a 2mm hex key. If, on the other hand, you feel too much "play" in the focuser when the thumbscrew is loosened, you may need to tighten these setscrews a bit.

**NOTE:** Upon receipt of your telescope, grasp the focuser then loosen the focuser rotation lock thumbscrew and attempt to rotate the focuser. If it rotates too freely or feels loose, you'll need to tighten the three focuser rotation setscrews using a 2mm hex key until you feel resistance

---

when rotating the focuser. Do the same for the 2" accessory collar.

If you do not plan to use one (or either) of the rotation interfaces, we recommend tightening down the adjacent three setscrews as well as the thumbscrew lock.

### Finder Scope Dovetail Shoe

The EON's focuser is equipped with a dovetail finder scope shoe that allows attachment of an optional Orion finder scope, reflex sight, mini guide scope, or the Orion Dual Finder Scope bracket (Figure 2A).

### Using 1.25" and 2" Accessories

Your EON refractor can accommodate both 1.25" and 2" accessories, including just about any eyepiece, diagonal, or camera. The focuser has a 2" accessory collar attached to the drawtube. This collar has a brass, non-marring compression ring and three thumbscrews for secure attachment of a diagonal or other 2" accessory. The included 2"-to-1.25" step-down adapter is also equipped with a compression ring to prevent scoring of your 1.25" accessory.

The telescope must be used with either a diagonal or extension tube in order for an eyepiece to reach focus. In most cases, you will be using a 90° star diagonal for visual use with an eyepiece. A camera will also likely require a 2" extension adapter to reach focus. An optional 3" field flattener can be used instead of an extension adapter, and is recommended for imaging with cameras having an APS-C sized sensor or larger.

To attach a 1.25" diagonal to your telescope:

1. Remove the dust cap from the 1.25" eyepiece adapter.
2. Insert the barrel of your diagonal or extension tube into the 1.25" eyepiece adapter.
3. Secure the barrel in place by firmly tightening the thumbscrew on the 1.25" eyepiece adapter.

To attach a 2" diagonal, or extension tube to your telescope:

1. Loosen the three thumbscrews on the focuser's 2" accessory collar and remove the 1.25" eyepiece adapter.
2. Insert the barrel of your diagonal or extension tube into the 2" accessory collar.
3. Secure the barrel in place by firmly tightening the thumbscrews.

## 4. Operating the EON f/7 Triplet

The EON 115mm and 130mm Triplet refractors are versatile telescopes designed for both high-performance imaging and visual pursuits. Their moderate f/7 focal ratio and premium ED optics combine to make them especially effective instruments for imaging with CCD or DSLR cameras.

Now that you have become familiar with the different features and functions of the telescope, you are ready to begin using it outside under a starry sky. Be sure to allow the telescope

to equilibrate to the outdoor temperature for at least ½ hour before using it; this ensures the best image quality.

### Connecting the EON to a Telescope Mount

The EON 115mm and 130mm Triplet refractors come with a pair of sturdy, hinged and felt-lined tube rings and a Vixen-style dovetail mounting bar. The tube rings have a large clamp knob to secure them tightly on the telescope tube. The rings also have multiple M6-1.0 threaded holes on the top and bottom bosses for attachment of dovetail bars or plates for coupling the telescope to a mount (on the bottom) and for piggy-backing a guide scope or second imaging or visual telescope on top of the EON.

Balancing the telescope can be done by moving the telescope forward or backward within the tube rings, or by sliding the dovetail mounting plate forward or backward in your mount's saddle.

### Extending the Dew Shield

The dew shield on the EON refractors should be extended prior to use of the telescope. The dew shield reduces the formation of dew on the outside surface of the objective lens and blocks off-axis ambient light from entering the telescope, which could reduce contrast and cause internal reflections. To extend the dew shield, loosen the dew shield thumbscrew lock a turn or so, then slide the dew shield forward until it stops. Then lightly re-tighten the thumbscrew.

### Observing with the EON f/7 Triplet

To observe with the EON 115mm or 130mm Triplet you will need either a 1.25" or 2" diagonal and an eyepiece, each sold separately. Because the optics are made with high-quality ED glass, the eyepieces you choose should also have excellent, fully multi-coated optics to leverage the full performance of the telescope. It is desirable to have a range of eyepieces of different focal lengths, to allow viewing over a range of magnifications.

To calculate the magnification, or power, of a telescope, simply divide the focal length of the telescope by the focal length of the eyepiece:

$$\text{Magnification} = \frac{\text{Telescope Focal Length (mm)}}{\text{Eyepiece Focal Length (mm)}}$$

If outside viewing conditions are ideal, a telescope with good optics can achieve a magnification of about 60x per inch, or 2.4x per millimeter, of aperture. Keep in mind that at higher powers, an image will always be dimmer and less sharp (this is a fundamental law of optics). In most cases the steadiness of the air (the "seeing") will limit how much magnification the scope can tolerate, rather than the telescope itself.

Always start viewing with your lowest-power (longest focal length) eyepiece in the telescope. After you have located and observed the object with it, you can try switching to a higher-power eyepiece to ferret out more detail, if atmospheric conditions permit. If the image you see is not crisp and steady, reduce the magnification by switching to a longer focal length eyepiece. As a general rule, a small but well-resolved image will show more detail and provide a more enjoyable view than a dim and fuzzy, over-magnified image.



### Imaging with the EON f/7 Triplet

Given their high-quality f/7 apochromatic optics, the EON 115mm and 130mm Triplets excel for astrophotography with a CCD or DSLR camera. To attach a DSLR camera, all you will need is the appropriate T-ring for the make and model of your camera, a 2" prime focus camera adapter or T-adapter, and (for the EON 130 only) a 2" extension tube (available from Orion). Simply attach the T-ring to the camera body and thread the 2" prime focus camera adapter onto the T-ring. Insert the barrel of the camera adapter into the 2" extension tube, then install the 2" extension tube in the 2" accessory collar of the focuser and secure it with the thumbscrews.

For the EON 115, no extension tube is needed. Just thread the T-ring for your specific DSLR camera onto the T-adapter and insert the barrel of the T-adapter into the 2" accessory collar of the focuser and secure it with the thumbscrews.

Most CCD cameras will have a 1.25" or 2" barrel ready to attach directly to your telescope like an eyepiece or diagonal. No adapter is required, simply insert the barrel of the CCD camera into the 1.25" adapter or 2" accessory collar and secure the camera with the thumbscrew(s). Depending on your camera, you may need to use an extension tube for your particular imaging setup. Any imaging accessory, such as a color filter wheel, increases the amount of inward focus travel required.

An optional field flattener is a desirable accessory to compensate for the inherent field curvature of optically fast, or moderately fast, refractors such as the EON 115 and 130. Orion carries a field flattener designed for use with both the EON 115 and 130 (available Fall 2015); see our website or call Orion customer service for more information. The flattener will ensure tight, sharp stars out to the edge of your imaging sensor, and is highly recommended if you are using a camera with an APS-C size sensor or larger. For visual use, a field flattener may not be necessary. For imaging sensors smaller than APS-C used with the EON, a field flattener may not provide any noticeable benefit.

#### Note about Chromatic Aberration

Chromatic aberration literally means color distortion. Whenever light passes through one material to another, different wavelengths (color) are bent by different amounts. This is a prob-



**Figure 3** The foam-fitted hard case keeps the EON telescope clean and well-protected. (EON 115 shown)

lem that plagues refractor-type telescopes, since light passes through both air and glass to form an image. Most astronomical objects emit a spectrum comprised of many different wavelengths of light, so each wavelength will be bent by a slightly different amount when passing through a lens. This results in each color of light reaching precise focus at a slightly different point, which will provide a soft image with a halo of unfocused color.

The EON Triplet apochromatic refractors are designed to minimize chromatic aberration. The three-element, air-spaced lens assembly includes one element made from high-performance FK-61 "extra-low dispersion", or ED, glass. The use of this ED glass largely eliminates chromatic aberration, resulting in a much more pleasing view as compared to typical achromatic, or two-element, refractors. Critical stellar or planetary observations become more accurate with this color correction since the focus is sharper, with no unfocused "false" color around the object. The ED triplet optics will render true, high-contrast images.

## 5. Care & Maintenance

Give your telescope reasonable care and it will last a lifetime. When not in use, keep the telescope in its padded case (**Figure 3**), and keep the objective dust cover on, as well as the small plastic plug on the 1.25" adapter. Store it indoors or in a dry garage. Do not leave the telescope outside except when using it. If a scratch appears on the tube, it will not harm the telescope. Smudges on the tube can be wiped off with standard household cleaners.

#### Dew

When you are ready to pack up your telescope at the end of the night, avoid immediately storing it if you encountered heavy dew and the telescope is damp. Instead, bring the telescope inside and allow the moisture on the telescope to evaporate. If dew forms on the objective lens, then leave the dust cover off of the telescope until all the moisture has evaporated. Once the telescope has completely dried out, place it back in its case.

#### Cleaning Optical Surfaces

In general, your telescope will only need to be cleaned on a very minimal basis. Dust particles on the objective lens do not affect the optical quality of your EON. Loose dust can simply be blown off with air, using a compressed air can or blower bulb. Any remaining dust is best left alone, unless the build up is extreme. Fingerprints and water marks should be cleaned from your telescope's objective lens. Any quality optical lens tissue and cleaning fluid specifically designed for multi-coated optics can be used to clean the telescope's objective lens as well as the lenses of your eyepieces and finder scope. Never use regular glass cleaner, or cleaning fluid designed for eyeglasses.

Before cleaning with fluid and tissue, however, blow any loose particles off the lens with a blower bulb or compressed air, or lightly brush the lens with a soft camel hair brush. Apply some cleaning fluid to a tissue, never directly on the optics. Wipe

---

the lens gently in a circular motion, then remove any excess fluid with a fresh lens tissue. Oily fingerprints and smudges may be removed using this method. Use caution; rubbing too hard may scratch the lens! Clean only a small area at a time, using a fresh lens tissue on each area. Never reuse tissues.

## 6. Specifications

### **EON 115 f/7 ED Triplet**

Optical tube:	Seamless aluminum
Optics:	Air-spaced Triplet, with one element FK-61 ED
Lens cell:	Machined aluminum
Aperture:	115mm (4.52")
Tube color:	Gloss white
Focal length:	805 mm
F-ratio:	7.0
Lens coatings:	Fully multi-coated (all air-to-glass surfaces multi-layer coated)
Tube baffles:	Multiple knife edge baffles
Tube length, dew shield retracted:	27.5" / 69.9 cm
Tube length, dew shield extended:	34.4" / 87.4 cm
Weight: (with tube rings and dovetail bar attached)	22.5 lbs. (with tube rings attached)/ 10.2 kg
Tube rings:	Split, felt lining, three M6x1.0 holes on upper and lower bosses
Finder:	3" Crayford focuser, 11:1 dual speed
Drawtube travel:	3.9" / 99 mm
Rotatable focuser:	Yes
Focus lock:	Yes
Dew shield:	Retractable
Finder scope:	Optional; installed dovetail finder scope shoe
2" accessory collar:	Brass compression ring
1.25" adapter:	Brass compression ring; glare threaded
Objective dust cover:	Aluminum, thread fit
Diagonal:	Not included
Eyepiece:	Not included
Field flattener:	Optional
Case:	Hard case with die-cut foam interior; outer dimensions 35" x 10.25" x 11.25" (88.9 cm x 26.0 cm x 28.6 cm)

---

### **EON 130 f/7 ED Triplet**

Optical tube:	Seamless aluminum
Optics:	Air-spaced Triplet, with one element FK-61 ED
Lens cell:	Machined aluminum
Aperture:	130mm (5.12")
Tube color:	Gloss white
Focal length:	910 mm
F-ratio:	7.0
Lens coatings:	Fully multi-coated (all air-to-glass surfaces multi-layer coated)
Tube baffles:	Multiple knife edge baffles
Tube length, dew shield retracted:	32" / 81.3 cm
Tube length, dew shield extended:	38" / 96.5 cm
Weight: (with tube rings and dovetail bar attached)	20.7 lbs. / 9.49 kg
Tube rings:	Two hinged, felt lined rings, multiple M6-1.0 holes top and bottom
Focuser:	3" Crayford focuser, 11:1 dual speed
Drawtube travel:	3.9" / 99 mm
Rotatable focuser:	Yes
Focus lock:	Yes
Dew shield:	Retractable
Finder scope:	Optional; installed dovetail finder scope shoe
2" accessory collar:	Brass compression ring
1.25" adapter:	Brass compression ring; glare threaded
Objective dust cover:	Aluminum, thread fit
Diagonal:	Not included
Eyepiece:	Not included
Field flattener:	Optional
Case:	Hard case with die-cut foam interior; outer dimensions 35" x 10.25" x 11.25" / 88.9 cm x 26.0 cm x 28.6 cm

---

## **One-Year Limited Warranty**

This Orion product is warranted against defects in materials or workmanship for a period of one year from the date of purchase. This warranty is for the benefit of the original retail purchaser only. During this warranty period Orion Telescopes & Binoculars will repair or replace, at Orion's option, any warranted instrument that proves to be defective, provided it is returned postage paid. Proof of purchase (such as a copy of the original receipt) is required. This warranty is only valid in the country of purchase.

This warranty does not apply if, in Orion's judgment, the instrument has been abused, mishandled, or modified, nor does it apply to normal wear and tear. This warranty gives you specific legal rights. It is not intended to remove or restrict your other legal rights under applicable local consumer law; your state or national statutory consumer rights governing the sale of consumer goods remain fully applicable.

For further warranty information, please visit [www.OrionTelescopes.com/warranty](http://www.OrionTelescopes.com/warranty).

### **Orion Telescopes & Binoculars**

**89 Hangar Way, Watsonville CA 95076**

**Customer Support Help Line (800) 676-1343 • Day or Evening**

© Copyright 2015 Orion Telescopes & Binoculars