

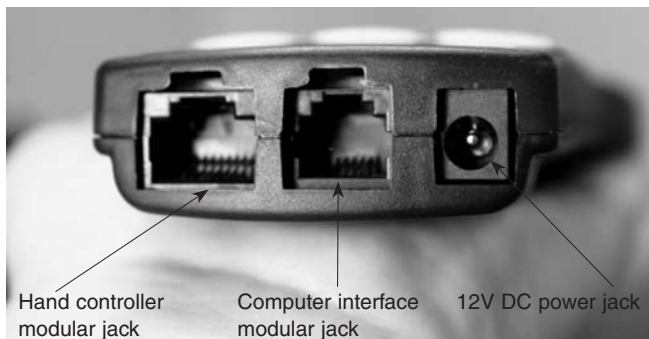
## 8. The Atlas GoTo Hand Controller

The EQ-G mounts equipped with the GoTo hand controller provide easy, computerized location of thousands of night sky objects such as planets, nebulae, star clusters, galaxies, and more for viewing through your telescope. The GoTo hand controller and internal dual-axis motors allow you to automatically point your telescope at a specific object, or tour the skies with pushbutton simplicity. The user-friendly menu allows automatic slewing to over 13,400 objects. Even inexperienced astronomers will find themselves quickly mastering the variety of features the GoTo hand controller offers in just a few observing sessions.

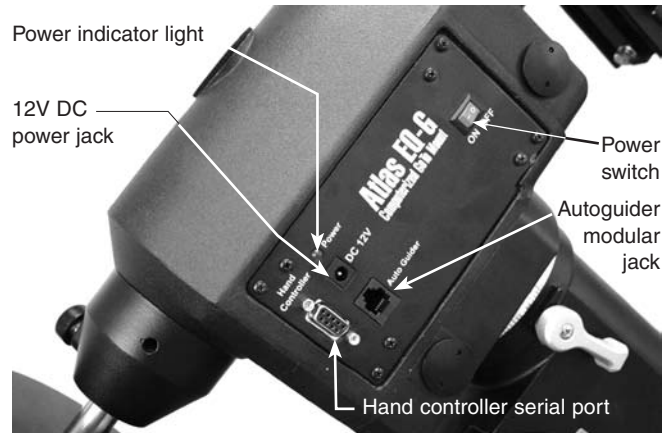
### Attaching the GoTo Hand Controller

The Atlas/Sirius EQ-G GoTo hand controller comes with two cables; one for usage with the Atlas EQ-G mount, while the other is for use with the Sirius EQ-G mount. After installation, you will have one of these cables left over. Feel free to discard this cable, as it will not be needed.

The cable for the Atlas EQ-G mount has a large, serial connector (DB-9) on one end and a smaller, modular connector (RJ-45) on the other. If you have the Atlas EQ-G mount, plug the modular connector of the hand controller cable into the hand controller (Figure 10). Push the connector into the jack until it clicks into place. Plug the serial connector into the mount (Figure 11a). Use the captive screws to secure the serial connector in place.

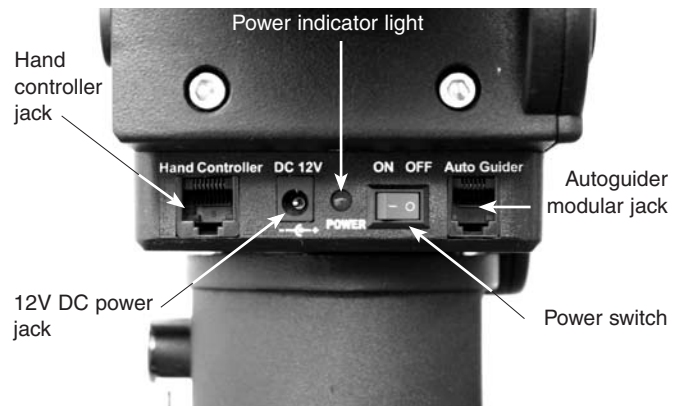


**Figure 10.** Hand controller jacks.



**Figure 11a.** Atlas EQ-G mount faceplate.

The hand controller cable for the Sirius EQ-G has modular connectors (RJ-45) on both ends. If you have the Sirius EQ-G mount, plug the modular connector on one end of the cable into the hand controller jack (Figure 10), and plug the modular connector on the other end of the cable into the mount's controller jack (Figure 11b). Push the connectors into the jacks until they click into place.



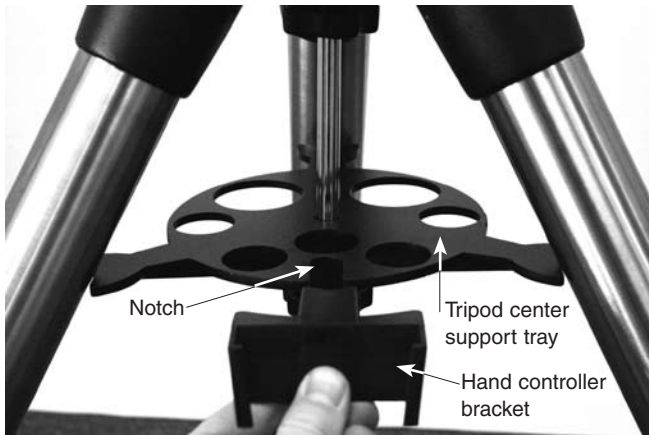
**Figure 11b.** The Sirius EQ-G control panel

The smaller modular jack on the hand controller (Figure 10) is used for RS-232 communications between the Atlas or Sirius EQ-G mounts and a computer equipped with astronomy software like Starry Night Pro (see "Linking with a Computer"). The 12V DC power jack on the hand controller allows independent

use of the GoTo hand controller for users who wish to browse the object database without connecting to the telescope mount (Figure 10). The power jack is also used when updating the firmware in the hand controller (see “Updating the GoTo Hand Controller’s Firmware”).

The included GoTo hand controller bracket attaches to the built-in notch in the tripod center support tray. To install the hand controller bracket, simply line up the tab on the back of the bracket with the notch in the tripod center support tray and slide the bracket forward until it clicks into place (Figure 12). You now have a place to put the GoTo hand controller while you are viewing.

You can reduce the chances of getting your hand controller cable tangled during use by installing the included wire clip. The clip also prevents mechanical strain on the hand controller cable when it is in use. The wire clip is adhesive backed for easy attachment to any convenient location on the mount.



**Figure 12.** Installing the hand controller bracket.

### Powering the Atlas EQ-G Mount

The Atlas EQ-G should be powered by an 11V to 15V DC power supply (tip positive) capable of producing continuous current of a minimum 2 amps. We recommend using a portable rechargeable battery, like the Dynamo or Dynamo Pro available from Orion.

If you are using a portable battery like the Orion Dynamo, use the 12V DC power cable supplied with your mount (male cigarette lighter plug on one end, standard 12V DC power plug on other end) to connect the battery to the 12V DC power jack on the mount (Figures 11a and 11b). Make sure the Dynamo’s power switch is in the “on” position after connecting. Then, to turn the mount (and GoTo hand controller) on, simply press the switch on the mount so it is in the “on” position.

*Note: The power indicator LED on the mount (near the power switch) will begin to flash when the battery power is low. When the battery power is extremely low, the LED will flash rapidly. Recharge or replace the battery as needed.*

### Functions of the GoTo Hand Controller

There are four main categories of control buttons on the GoTo hand controller (Figure 13):



**Figure 13.** The GoTo hand controller.

1. Mode buttons
2. Directional buttons
3. Scroll buttons
4. Dual Purpose buttons

#### Mode Buttons

The three mode buttons are located at the top of the controller, directly below the LCD screen. They include the **ESC**, **ENTER**, and **SETUP** buttons.

The **ESC** button is used to escape from a certain command or go back a level in the menu tree.

The **ENTER** button is used to select the functions and sub-menus in the menu tree, and to confirm certain functional operations.

The **SETUP** button is a “hot key” that takes you to the Setup Menu.

#### Directional Buttons

The directional buttons allow the user to have complete motion control of the Atlas/Sirius EQ-G mount at almost any step in operation. These controls are locked out when the mount is slewing to an object. The directional buttons are very helpful when initially aligning the mount, centering objects in the eyepiece field of view, and manual guiding. The directional buttons are typically used in conjunction with the **RATE** button. The left and right directional buttons can also be used to move the text cursor when entering data into the hand controller.

## Scroll Buttons

The up and down scroll buttons allow you to scroll up and down within the menu tree or selections displayed on the hand controller screen.

## Dual Purpose Buttons

The dual purpose buttons serve two distinct purposes. They are used for data entry and as quick reference keys.

**TOUR** button: Takes you on a preset tour of the best night sky objects visible

**RATE** button: Changes the speed of the motors when the directional buttons are pressed. There are 10 speeds to choose from, with 0 being the slowest and 9 being the fastest.

**UTILITY** button: “Hot key” access to the Utility Functions menu.

**USER** button: Enter or recall coordinates for up to 25 objects in the User Defined database.

**ID** button: Identifies the object the mount is currently pointing to.

**NGC, IC, M, Planet,** and **Object** buttons: Allow direct access to catalogs and databases of over 13,400 objects.

# GoTo Hand Controller Operation

This section provides a guide for initial setup and alignment of the Atlas/Sirius EQ-G mount with the GoTo hand controller.

## Initial Setup

1. Perform the polar alignment using the procedure previously outlined in Section 6 of the instruction manual that came with your Atlas/Sirius EQ-G mount. A rough polar alignment will suffice, but an accurate polar alignment using the polar axis finder scope will increase tracking accuracy (and pointing accuracy for one-star alignments).
2. Rotate the telescope tube about the mount's declination axis so the tube is parallel with the mount's R.A. axis (and the front of the tube is pointed to the sky, not the ground). Rotate the mount's R.A. axis so the counterweight shaft is pointed straight down. The telescope and mount should now appear as shown in Figure 14. This will be called the “home” position of the mount.

*Note: Once the mount is initially set to its “home” position, the mount should not be moved manually. Otherwise, the GoTo hand controller will lose track of the mount's position, and the alignment procedure will need to be performed again. Keep both the R.A. and Dec. lock levers engaged.*

3. Turn on the power switch on the mount
4. The initial screen displayed on the hand controller is the version screen. Press **ENTER** to proceed.



**Figure 14.** The telescope and mount in their “home” position

5. The hand controller's LCD screen will show a safe solar viewing warning message. Press the **ESC** button to continue.

*Note: The GoTo hand controller's LCD backlighting will become dim and the illuminated buttons will turn off if left idle for 30 seconds. Pressing any button will re-illuminate the hand controller.*

6. Enter your observing site's longitude and latitude coordinates. First enter the longitude coordinate and hemisphere, followed by the latitude coordinate and hemisphere. Use the numerical keypad to enter the digits, and use the left and right directional buttons to move to the next digit. Use the scroll buttons to choose W or E (for longitude) and N or S (for latitude). If you do not know the longitude and latitude coordinates of your viewing location, consult an atlas or geographical map of your area. Press **ENTER** to confirm your coordinates.

---

*Note: Longitude and latitude coordinates must be entered in degrees and arcminutes. If your map or atlas gives coordinates in decimal values (i.e. latitude = 36.95 N) you must convert into degrees and arcminutes (i.e. latitude 36.95 N = latitude 36°57' N).*

*Note: If a mistake is entered into the hand controller during the initial setup procedure, press the **ESC** button to go back to the previous screen.*

7. Enter the time zone in which you are observing in hours (see Appendix D in the Atlas/Sirius EQ-G instruction manual), using the scroll buttons (+ for east of Prime Meridian, - for west of Prime Meridian) and numeric keypad. Use the left and right directional buttons to move to the next digit. Press **ENTER** to confirm your choice.
8. Enter the date in mm/dd/yyyy format using the numeric keypad. Use the left and right directional buttons to move to the next digit. Press **ENTER** to confirm your choice.
9. Enter your current local time using the 24 hour clock format (example: 2:00PM = 14:00). Press **ENTER** to view the time you entered. If the time is incorrect, press **ESC** to go back to the previous screen. If the time is correct, press **ENTER** again.
10. If the date entered in step 8 falls between March and November, the hand controller will ask "DAYLIGHT SAVING?" on the LCD screen. Use the scroll buttons to select "YES" or "NO" to indicate if you are currently on Daylight Savings Time or not, and press **ENTER**.
11. The hand controller will now display "Begin Alignment?" Press **1** or **ENTER** to start the alignment procedure. Press **2** or **ESC** to skip the alignment and exit to the Main Menu.

You are now ready to begin the alignment procedure.

### **Alignment**

In order for the GoTo hand controller to accurately locate and point to objects in the sky, it must first be aligned on known positions (stars). With the supplied information, the controller can replicate a model of the sky and the movements of astronomical objects.

There are three ways to align depending on your demand for accuracy. If you are using the GoTo controller for the first time, we recommend you begin with the three-star alignment. In most cases, a three-star alignment produces the most accurate alignment among the three methods. The description below will lead you through a step-by-step procedure on how to perform the three-star alignment.

*Note: Before performing any of the alignment methods, be sure your finderscope is well aligned with the telescope tube.*

### **Three-Star Alignment**

1. From the alignment screen, select "3-Star Align" using the scroll buttons. Press **ENTER** to confirm your choice.
2. The hand controller will provide a list of stars available in your current sky for you to choose as the first alignment

star. Choose a star you are familiar with using the scroll buttons. Press **ENTER** to confirm your choice. The mount will start slewing the telescope towards the chosen object. When the telescope stops slewing, adjust its position using the controller's directional buttons until the chosen star is centered on the crosshairs of the finderscope. Now look in the eyepiece and adjust the position of the telescope (again using the directional buttons) so the chosen star is centered in the field of view of the eyepiece. Press **ENTER** to confirm the star is centered.

*Note: The slewing speed can be adjusted by pressing the **RATE** button. Choose a desired rate between 0 (slowest) and 9 (fastest).*

*Note: The hand controller will make a "beep" sound once it has finished slewing to an object. Do not try to adjust the telescope before you hear the "beep" sound. The controller will only respond to the **ESC** button while slewing (which stops the slewing).*

3. The controller will provide a list of stars that can be used as the second alignment star. Choose a star using the scroll buttons and press **ENTER** to confirm your choice. Repeat the centering procedure for the second alignment star using the directional buttons and press **ENTER** to confirm alignment.
4. The controller will once again provide a list of stars that can be used as the third alignment star. Choose a star using the scroll buttons and press **ENTER** to confirm your choice. Once again, repeat the centering procedure for the third alignment star and press **ENTER** to confirm alignment.
5. Once the three alignment stars have been entered and alignment is completed, the hand controller will display "Alignment Successful." Press **ENTER** to access the Main Menu. Otherwise, "Alignment Failed" will be displayed, and the alignment procedure must be performed again. To do this, turn the mount's power switch off, then on again.

### **Two-Star Alignment**

Two-star alignment requires only two alignment stars but may produce lesser pointing accuracy than the three-star alignment. The description below will lead you on a step-by-step procedure on how to perform the two-star alignment.

1. From the alignment screen, select "2-Star Align" using the scroll buttons. Press **ENTER** to confirm your choice.
2. The hand controller will provide a list of stars available in your current sky for you to choose as the first alignment star. Using the scroll buttons, choose a star you are familiar with and press **ENTER** to confirm your choice. The mount will start slewing the telescope towards the chosen star. When the telescope stops slewing, adjust its position with the controller's directional buttons until the star is centered on the crosshairs of the finderscope. Now look in the eyepiece and adjust the position of the telescope (again using the directional buttons) so the chosen star is centered in the field of view of the eyepiece. Press **ENTER** to confirm the star is centered.

3. The controller will provide a list of stars that can be used as the second alignment star. Choose a star using the scroll buttons and press **ENTER** to confirm your choice. Repeat the centering procedure for the second alignment star and press **ENTER** to confirm alignment.
4. Once the two alignment stars have been entered and alignment is complete, the hand controller will display "Alignment Successful." Press **ENTER** to access the Main Menu. Otherwise, "Alignment Failed" will be displayed, and the alignment procedure must be performed again. To do this, turn the mount's power switch off, then on again.

### One-Star Alignment

One-star alignment is the simplest and quickest alignment method, as only one alignment star is required. Due to minimal data input, however, a one-star alignment will not yield optimal results unless polar alignment is very accurate, and any cone error is minimized (see Appendix A). The description below will lead you on a step-by-step procedure on how to perform the one-star alignment.

1. From the alignment screen, select "1-Star Align" using the scroll buttons. Press **ENTER** to confirm your choice.
2. The hand controller will provide a list of stars available in your current sky for you to choose as the first alignment star. Using the scroll buttons, choose a star you are familiar with and press **ENTER** to confirm your choice. The mount will start slewing the telescope towards the chosen star. When the telescope stops slewing, adjust its position with the controller's directional buttons until the star is centered on the crosshairs of the finderscope. Now look in the eyepiece and adjust the position of the telescope (again using the directional buttons) so the chosen star is centered in the field of view of the eyepiece. Press **ENTER** to confirm the star is centered.
3. Once the alignment star has been entered and alignment is complete, the hand controller will display "Alignment Successful". Press **ENTER** to access the Main Menu.

### Tips for Choosing Alignment Stars

If possible, use the following tips when choosing alignment stars for best pointing accuracy.

One-star alignment: Choose a star close to the Celestial Equator (Dec close to 0°).

Two-star alignment: Choose two stars on the same side of the meridian, and at least 3 hours apart in right ascension and 3° apart in declination. If you suspect your polar alignment is poor, choose two stars that are 20° to 60° apart in declination.

Three-star alignment: For the first two stars, follow the tip above for two-star alignment. For the third alignment star, choose a star on the other side of the meridian. The first and third alignment stars should have declination coordinates between +30° and +70° or between -30° and -70°.

### Pointing Accuracy Enhancement (PAE)

The three-star alignment should provide excellent pointing accuracy for visual observation. For other applications, such as CCD imaging, even better pointing accuracy can be obtained in a specific region of the sky by use of the Pointing Accuracy Enhancement (PAE) function. Perform the following procedure to use the PAE function.

1. Choose a bright star near the area of interest in the night sky. Consult a planisphere or software program to choose this bright star, if necessary.
2. Find this star in the hand controller's object database. This is easily done by pressing the **OBJECT** button, which will take you directly to the Named Star database. Press **ENTER** to access the list of named stars. Use the scroll buttons to peruse the list, and press **ENTER** to select the star. Press **ENTER** again, and the LCD will ask "View Object?" Press **ENTER** to issue a command to the mount to GoTo the star. If the mount is under the control of a computer running planetarium software, click on the star to slew the mount to it.
3. Use the directional buttons (and **RATE** button) to accurately center the star in a high-powered eyepiece (10mm or less focal length).
4. Press the **ESC** button, then press and hold the **ESC** button for 2 seconds. The hand controller LCD will read "Re-center", and the name of the chosen bright star will blink three times. If the GoTo command was sent by a computer running planetarium software, the LCD will read "Last goto object" instead of the star's name.
5. Make sure the chosen star is still centered in the eyepiece, and press the **ENTER** button. If you don't want to record the star position, press the **ESC** button to exit the PAE function.

After the PAE function is performed, the hand controller will recalculate its model of the sky. The pointing accuracy in the area of sky around the chosen bright star should now be improved. To improve pointing accuracy in another region of the sky, perform the PAE function again, this time choosing a bright star in the new region of interest.

*Note: If the mount is "parked" before it is powered off (see "Utility Functions"), the star alignments and PAE corrections will remain stored in the hand controller. As long as the mount is not moved between usage, the alignment will not need to be performed again when the mount is subsequently powered on.*

## Object Catalog

The GoTo hand controller boasts a vast database of over 13,400 object coordinates and information. The database contains the following catalogs:

**Named Star** - A list of 212 well-known bright stars.

**Solar System** - The other 8 planets of our solar system, and the Moon.

---

**NGC** - 7,840 of the brightest deep sky objects from the NGC 2000.0 database (edited by Roger W. Sinnott, copyright by Sky Publishing Corp., used with permission).

**IC** - 5,386 objects from the Index Catalog.

**Messier** - Complete list of all 110 Messier objects. These are some of the most spectacular objects to view in the night sky.

**Caldwell** - Complete list of all 109 Caldwell objects.

**Double Stars** - Includes 55 of the best double stars to view.

**Variable Stars** - Includes 20 of the most well-known variable stars.

**User Defined** - Up to 25 objects can be saved in the User Defined database (see "Using the User Defined Database").

### Selecting an Object

Once the telescope has been aligned, you can access and view the variety of different objects in the GoTo hand controller's database. There are three methods of selecting a celestial object to view.

#### 1. Shortcut Buttons

**TOUR:** Takes you on a preset tour across the night sky. The brightest and most beautiful deep-sky objects will automatically be chosen by the hand controller for your viewing pleasure. Use the scroll buttons to view the different deep-sky objects that are available for viewing through the tour function. Choose the desired object by pressing **ENTER**. The LCD screen will display the coordinates of the chosen object. Press **ENTER** again, and the hand controller will ask "View Object?" Press **ENTER** once more to have the telescope slew to the object.

**M, NGC, IC:** These shortcut buttons give you direct access to the most popular celestial catalogs. Use the numeric buttons to select an object by entering its catalog number. Pressing **ENTER** will display its coordinate. Primary information such as size, magnitude, and constellation are obtained by pressing the scroll buttons. Press **ENTER** again, and the hand controller will ask "View Object?" Press **ENTER** once more to have the telescope slew to the object.

**PLANET:** This shortcut button takes you straight to the Planets submenu in the hand controller's database. Use the scroll buttons to scroll through the list of planets (and the Moon) in our solar system. Press **ENTER** to display the chosen planet's coordinates. Press **ENTER** again, and the hand controller will ask "View Object?" Press **ENTER** once more to have the telescope slew to the object. If the planet you selected is currently below the horizon, the hand controller will prompt you to make another choice.

**USER:** This shortcut button will take you to the database that you have defined for yourself. You can enter a new location or recall the objects that have been previously saved (see "Using the User Defined Database").

#### 2. Object Button

The **OBJECT** button takes you to the Objects Catalog, where you have complete access to all of the celestial objects in the

database. Simply scroll through the object catalogs using the scroll buttons and choose the catalog of objects you wish to view. Press **ENTER** to confirm your choice. Use the scroll buttons to choose an individual object within the catalog and press **ENTER** a second time to display the object's coordinate. Press **ENTER** again, and the hand controller will ask "View Object?" Press **ENTER** once more to have the telescope slew to the object.

#### 3. Menu

You can also access the Objects Catalog through the Main Menu. In the Main Menu, scroll down to "Object Catalog" and press **ENTER**. Like the **OBJECT** button, this gives you complete access to the 13,400 celestial objects in the hand controller's database.

## Other Functions

The GoTo hand controller is equipped with a variety of additional functions that allow you to optimize performance and access other features of the system.

### Utility Functions

Utility Functions are useful tools that provide simple, yet handy, processes to enhance your observing experience.

**Show Position:** Displays the coordinates (right ascension and declination) of the location where the telescope is currently pointing.

**Display Time:** Displays the local time and local sidereal time.

**Park Scope:** Moves the telescope to the "home" position. This allows you to power off the Atlas/Sirius EQ-G mount while saving alignment and PEC training data. When subsequently powered on, the initial setup information must again be entered (be sure to enter the current time accurately!), but the alignment procedure can be skipped.

**Inquire Version:** Displays the hardware, firmware, and database version of the GoTo hand controller. If the hand controller is connected to the mount, this will also display the firmware version of the motor control board. Use the scroll buttons to view the version numbers.

**PEC Training:** See Appendix B for information

**LCD/LED Tuning:** Allows adjustments of the LCD character contrast, the LCD backlighting, and the LED backlighting of the pushbuttons. Use the scroll buttons to select which of these you wish to adjust. Use the left and right directional buttons to increase or decrease the value.

### Setup Functions

The Setup functions allow you to change any system variable or information regarding location, time, date, and alignment. To access the Setup functions, either press the **SETUP** button on the hand controller or scroll to "Setup Mode" from the Main Menu using the scroll buttons and press **ENTER**. The different types of functions available to you are listed below, along with their respective purposes.

---

**Date:** Allows you to change the date entered during the initial setup.

**Time:** Allows you to change the current time.

**Observing site:** Allows you to change the current location (longitude and latitude) setting.

**Daylight Savings:** Allows you to change the Daylight Savings option.

**Alignment:** Allows you to re-perform the star alignment, (see "Alignment").

**Set Backlash:** This function allows you to insert a value for each axis to compensate for slewing backlash experienced on that axis. Backlash is a delay in motorized motion of the mount due to slack between gears. Backlash is experienced when the slewing direction is reversed on one or both axes of motion. For improved pointing accuracy, it is important the backlash value is set to be equal or greater than the actual amount of backlash between the gears. The default value for the backlash compensation is 0° 10' 0" (0 degrees, 10 arcminutes, 0 arcseconds). Use the numeric pushbuttons to enter the desired backlash compensation value. First set the value for R.A. backlash compensation, then press **ENTER** to set the value for DEC. Press **ENTER** again to return to the Setup Menu.

*Note: Backlash compensation is only active for computerized slewing, not for manual slewing with the directional buttons.*

#### **Set Tracking:**

-Sidereal Rate: Activates tracking at sidereal rate. This is the default tracking rate.

-Lunar Rate: Activates tracking at lunar rate.

-Solar Rate: Activates tracking at solar rate.

-PEC + Sidereal: Activates sidereal rate tracking with Periodic Error Correction.

-Stop Tracking: Stops tracking.

**Auto Guide Speed:** When using an autoguider, this sets the guiding speed to 1.125x, 1.25X, 1.5X, 1.75X, or 2X sidereal rate.

#### **Using the User Defined Database**

The GoTo hand controller allows you to save up to 25 objects in the User Defined database. You can save unidentifiable objects, current comet and/or asteroid positions, or make a custom list of your favorite objects to view.

#### **Saving an Object to the Database**

1. Press the **USER** button. You can also select "User Defined" in the Object Catalog menu and then press **ENTER**.
2. Use the scroll buttons to select "Input Coordi." and press **ENTER**.
3. You can **ENTER** the object's location by its R.A. and Dec. coordinates, or its azimuth and altitude coordinates. Press **1** (RA-Dec) or **2** (AzAlt) to make your selection.
4. The default setting will display the R.A./Dec. or Az/Alt coordinates the telescope is currently pointed to. Therefore, if

the telescope is pointing at the object you wish to save (i.e. the object is centered in the eyepiece), simply press **ENTER**. If the object you wish to save is at another location in the sky, enter its coordinates using the numeric keypad. When finished inputting the coordinates, press **ENTER**.

*Note: If the coordinates entered do not exist, the hand controller will not respond when **ENTER** is pressed. Check the coordinates for data entry mistakes, and re-enter the correct coordinates.*

5. The hand controller will then ask "Save?" If you do wish to save the entered object coordinates, press **ENTER**. Otherwise, press **ESC**.
6. The controller will now prompt you to choose a number between 1 and 25 for your chosen object. Using the scroll buttons, select a number you wish to represent the object, then press **ENTER**. Keep in mind that if the object is assigned a User Object number that is already in use, the hand controller will overwrite the previously saved coordinates.
6. The hand controller will now display "View Object?" Press **ENTER** to slew the telescope to the object, or press **ESC** to exit.

#### **Recalling a User Defined Object**

1. Press the **USER** button. You can also select "User Defined" in the Object Catalog menu and then press **ENTER**.
2. Choose "Recall Object" and press **ENTER**.
3. Select the User Object number representing the object you wish to view using the scroll buttons. Press **ENTER** to display the object's coordinate. Press **ENTER** again, and the hand controller will ask "View Object?" Press **ENTER** once more to have the telescope slew to the object. (If a vacant User Object number is selected, the hand controller will not respond.)

*Note: If the recalled User Object is currently below the horizon, the controller will display "Below Horizon!! Try another obj." and will automatically return to "Recall Object".*

#### **Identifying an Unknown Object**

The GoTo hand controller has the ability to identify celestial objects that are unknown to you. To identify an object the telescope is pointing at, simply press the **ID** button. You can also scroll to "Identify" in the Main Menu and press **ENTER** to identify the object. The hand controller will then show a list containing the close objects in the M, IC, NGC, and Named Star catalogs and their angular distance from the location where the telescope is pointed. Use the scroll buttons to view this list of objects. Press **ESC** when finished.

#### **Linking with a Computer**

The GoTo hand controller can be connected to a computer via the supplied computer interface cable. Many commercially available planetarium software programs can utilize this function and be used to control the Atlas/Sirus EQ-G mounts. Look for software that is compatible with the Celestron NexStar

5i/8i or NexStar GPS, like Starry Night Pro. The description below will lead you through the procedure on how to connect and disconnect the Atlas EQ-G to a computer.

1. Align the mount as described previously (see "Alignment").
2. Connect the supplied computer interface cable to the smaller modular jack (RJ-11) on the hand controller (Figure 10). Connect the other end of the cable to the COM port of your computer.
3. In the planetarium software of your choice, choose "Celestron NexStar 5i" or "Celestron 8/9/11 GPS" for the driver setup and follow the instructions provided by the program to connect the mount and computer through the hand controller. The mount will be under the full control of your computer once the connection is successfully established.
4. When finished observing, follow the software's instructions to close the computer connection to the hand controller.

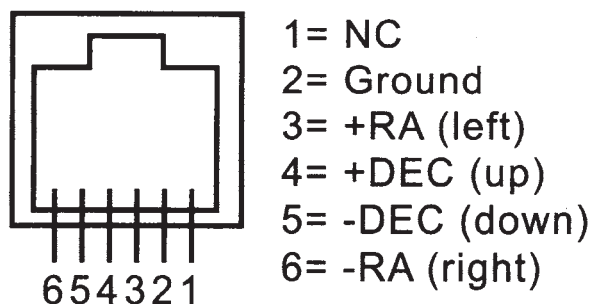
See Appendix C for more information on computer interfacing.

### Auto Guiding

For astronomical imaging, the Atlas/Sirius EQ-G mounts have a designated autoguider jack (Figures 11a-b). The pin-outs on the 6 pin modular jack are SBIG compatible and can be used with most autoguiders available. Refer to Figure 15 when connecting the autoguider cable to the mount and calibrating the autoguider. Autoguiding speed can be adjusted using the "Auto Guide Speed" function in the Setup Menu.

### Updating the GoTo Hand Controller's Firmware

From version 3.0 and up, the GoTo hand controller's firmware can be updated over the internet. Users can download firmware updates from Orion's website [www.OrionTelescopes.com](http://www.OrionTelescopes.com).



**Figure 15.** Pin diagram for the Atlas EQ-G autoguider jack.

### System Requirements

- GoTo hand controller version 3.0 or greater
- Windows95 or later
- An available RS-232 COM port on the PC

- Computer interface cable (supplied)
- DC power supply (7.5V to 15V @ 100mA or greater output with 2.1mm tip positive plug)

### Preparing the Computer for the Update

1. Create a folder where you will store the files necessary for the update.
2. Go to the website [www.OrionTelescopes.com](http://www.OrionTelescopes.com), and access the support page for the Sirius/Atlas EQ-G mounts.
3. Download and save the Firmware Loader program to the folder you have created on your computer. You will need to download this program only once; after it is saved on your computer, only the firmware data file is needed for future updates.
4. Download and save the firmware update data file to the folder you created. The file will be named OrionVxxxxEQ.ssf, where xxxx indicates the version number of the firmware.

### Updating the GoTo Hand Controller

1. Plug the modular plug end of the computer interface cable into the middle jack in the hand controller (Figure 10). Plug the serial connector end of the cable to the COM port on your PC.
2. Press and hold down the 0 and 8 numerical buttons simultaneously, then plug the power supply into the hand controller's DC power jack. The hand controller will beep and display "SynScan Update Ver. x.x" on the LCD screen.
3. Run the Firmware Loader program on your computer.
4. Click on the "Browse" box and select the OrionVxxxx.ssf file location where it was saved previously on your computer.
5. Click on the "Update" button, and the new firmware will begin loading into the hand controller. The Firmware Loader will show the progress of the update on your computer screen. It will usually take approximately 5 minutes for the new firmware to load into the hand controller. It may take significantly longer if a serial-to-USB adapter is employed on your computer.
6. When the download is complete, the Firmware Loader will display "Update Complete".

The firmware in the GoTo hand controller has now been updated. You can click on the "HC. Version" button to confirm the new version number of the firmware (and possibly the database, but the hardware version will not change with internet updates).

*Note: If the error message "Can not connect to a SynScan hand control" appears on your computer, check all cable connections. Also, try closing all other computer programs that might be attempting to use the COM port.*

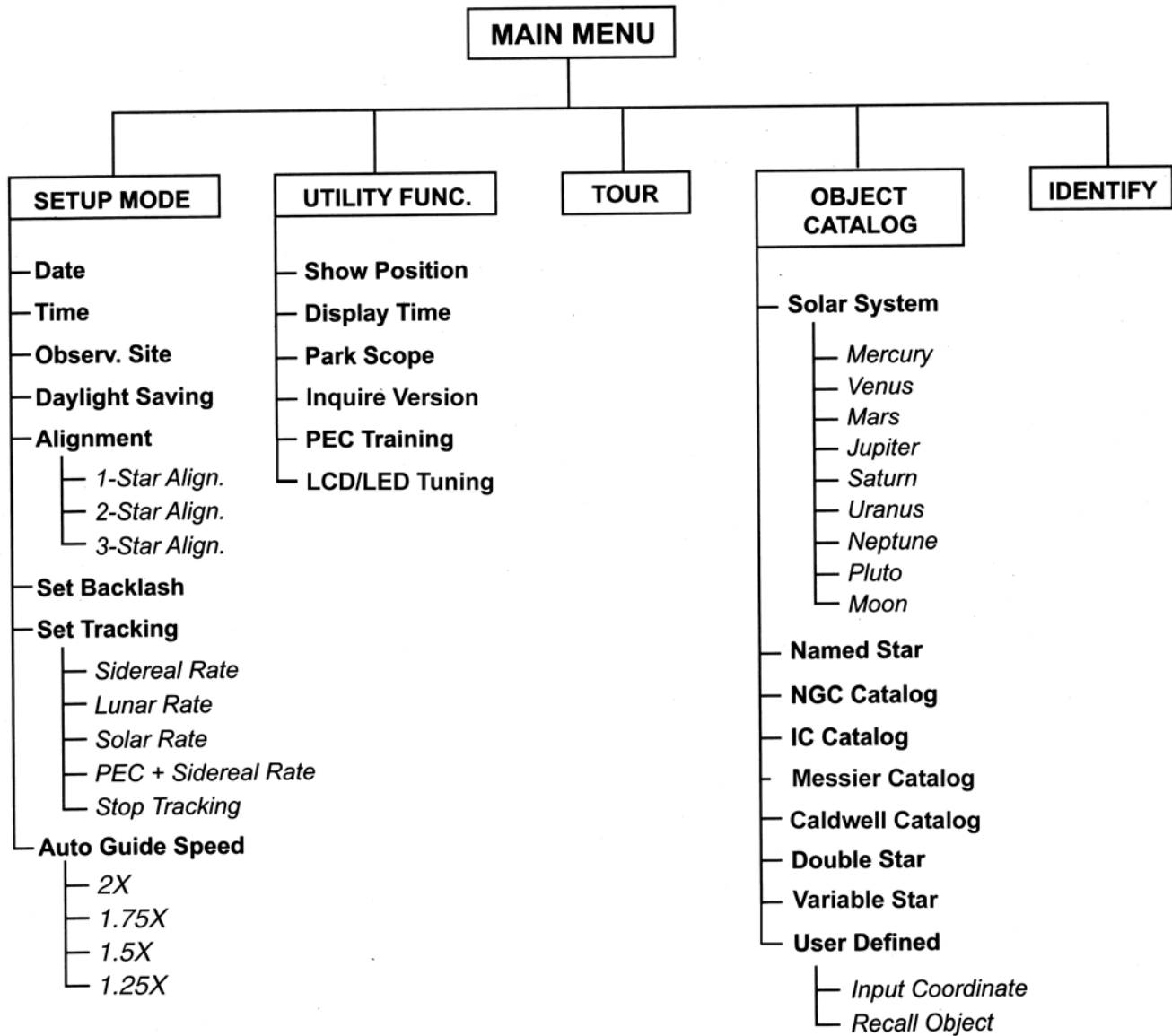
*Note: If the error message "Firmware update failed..." appears on your computer, remove the power plug from the hand controller, and then reconnect it. Now, repeat the firmware update procedure.*



---

By default, the data communication rate between the GoTo hand controller and the computer is 115kbps. The RS-232 port on some PCs may not support this high data transfer rate. If the firmware update procedure fails after a few tries, try reducing the data transfer rate by pressing the SETUP button on the hand controller. This will reduce the data transfer rate to 9.6kbps. The controller's LCD screen will show "Lo" in the lower right hand corner to indicate the lower transfer rate setting. The firmware update procedure remains the same except it will take much longer for the firmware to load into the hand controller.

# Atlas EQ-G GoTo Hand Controller Menu Tree



# Appendix C: RS-232 Connection

The Atlas/Sirius EQ-G mounts equipped with the GoTo hand controller are designed to receive commands sent from a computer's RS-232 COM port (via the computer interface cable). The hand controller will communicate with the computer at 9600 bits/sec, no parity, no stop bit. All angles are communicated with 16 bits and communicated using ASCII hexadecimal. The chart below shows the ASCII commands from the PC, and what the hand controller's response will be.

## Additional RS-232 Commands

### Sending a Tracking Rate

1. Multiply the desired tracking rate (arcseconds /second) by 4. For example: if the desired track rate is 120 arcseconds/second (approximately 8 times sidereal rate), then the TRACKRATE = 480.
2. Separate TRACKRATE into two bytes, such that (TRACKRATE = TrackRateHighByte\*256 + TrackRateLowByte). For example, if TRACKRATE = 480, then TrackRateHighByte = 1 and TrackRateLowByte = 224.
3. To send a tracking rate, send the following 8 bytes:
  - a. Positive Azm tracking: 80, 3, 16, 6, TrackRateHighByte, TrackRateLowByte, 0, 0
  - b. Negative Azm tracking: 80, 3, 16, 7, TrackRateHighByte, TrackRateLowByte, 0, 0
  - c. Positive Alt tracking: 80, 3, 17, 6, TrackRateHighByte, TrackRateLowByte, 0, 0

- d. Negative Alt tracking: 80, 3, 17, 7, TrackRateHighByte, TrackRateLowByte, 0, 0

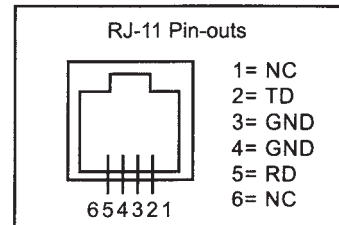
4. The number 35 is returned from the hand controller.

### Sending a Slow-GoTo Command

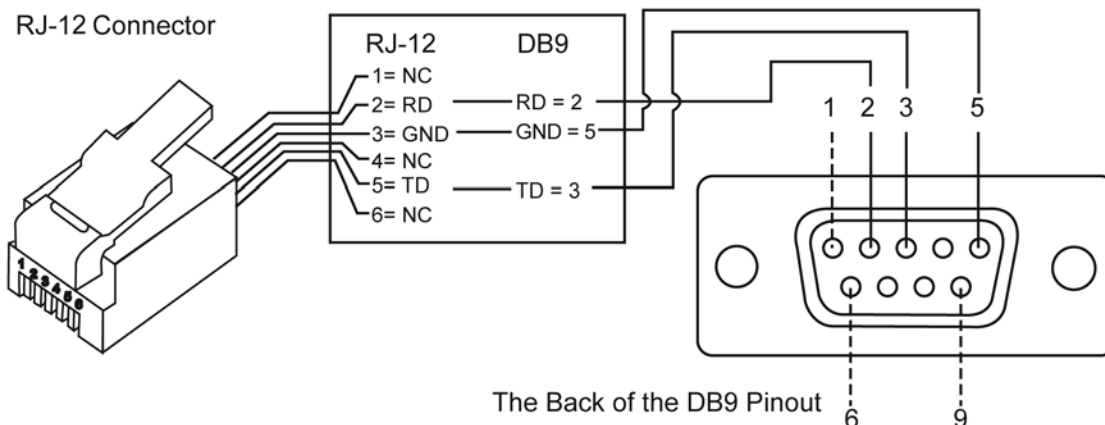
1. Convert the angle position to a 24 bit number. Example: if the desired position is 220, then POSITION\_24BIT =  $(220/360)*224 = 10,252,743$
2. Separate POSITION\_24BIT into three bytes such that (POSITION\_24BIT = PosHighByte \* 65536 + PosMedByte \* 256 + PosLowByte). Example: PosHighByte = 156, PosMedByte = 113, PosLowByte = 199
3. Send the following 8 bytes:
  - a. Azm Slow Goto: 80, 4, 16, 23, PosHighByte, PosMedByte, PosLowByte, 0
  - b. Alt Slow Goto: 80, 4, 17, 23, PosHighByte, PosMedByte, PosLowByte, 0
4. The number 35 is returned from the hand controller.

### Resetting the Position of Azimuth or Altitude

1. Convert the angle position to a 24bit number, same as Slow-Goto example.
2. Send the following 8 bytes:
  - a. Azm Set Position: 80, 4, 16, 4, PosHighByte, PosMedByte, PosLowByte, 0
  - b. Alt Set Position: 80, 4, 17, 4, PosHighByte, PosMedByte, PosLowByte, 0
3. The number 35 is returned from the hand controller.



## Physical Connection Diagram





**Customer Support (800) 676-1343**  
**E-mail: [support@telescope.com](mailto:support@telescope.com)**  
Corporate Offices (831) 763-7000  
P.O. Box 1815, Santa Cruz, CA 95061