

# INSTRUCTION MANUAL

## Orion® Atlas™ 10 EQ

#9874 Equatorial Reflector Telescope



 **ORION®**  
**TELESCOPES & BINOCULARS**  
*Providing Exceptional Consumer Optical Products Since 1975*

Customer Support (800)-676-1343  
E-mail: [support@telescope.com](mailto:support@telescope.com)  
Corporate Offices (831)-763-7000  
89 Hangar Way, Watsonville, CA 95076  
**OrionTelescopes.com**



**Figure 1a.** The Atlas 10 EQ.

*Congratulations on your purchase of a quality Orion telescope. Your new Atlas 10 EQ is designed for high-resolution viewing of astronomical objects. With its precision optics, and its superb Atlas mount, you'll be able to locate and enjoy thousands of fascinating celestial denizens, including planets, Moon, and a variety of galaxies, nebulas and star clusters. The built in dual internal DC stepper motor drives will easily track these objects as they move through the night sky.*

These instructions will help you set up and properly use your telescope. Please read them over thoroughly before getting started.

## Table of Contents

1. Unpacking . . . . .	3
2. Parts List . . . . .	3
3. Assembly . . . . .	3
4. Balancing the Telescope . . . . .	5
5. Using Your Telescope . . . . .	6
6. Setting Up and Using the Equatorial Mount. . . . .	7
7. Collimating . . . . .	12
8. Astronomical Observing . . . . .	14
9. Astrophotography . . . . .	17
10. Care and Maintenance . . . . .	18
11. Specifications . . . . .	19

## 1. Unpacking

The entire telescope will arrive in three boxes, one containing the tripod, one containing the equatorial mount, and the third box containing the optical tube. Be careful unpacking the boxes. We recommend keeping the boxes and original packaging. In the event that the telescope needs to be shipped to another location, or returned to Orion for warranty repair, having the proper packaging will ensure that your telescope will survive the journey intact.

Make sure all the parts in the Parts List are present. Be sure to check each box carefully, as some parts are small.

**WARNING:** *Never look directly at the Sun through your telescope or its finder scope—even for an instant—without a professionally made solar filter that completely covers the front of the instrument, or permanent eye damage could result. Young children should use this telescope only with adult supervision.*

If anything appears to be missing or broken, immediately call Orion Customer Support (800-676-1343) or email support@telescope.com for assistance.

## 2. Parts List

### Box #1

- 1 Tripod
- 3 Counterweights
- 1 Tripod support tray

### Box #2

- 1 Equatorial mount
- 1 Hand controller
- 1 Battery pack
- 1 Nylon hook-and-loop adhesive strip

### Box #3

- 1 Optical tube
- 2 Tube rings
- 1 Tube ring mounting plate
- 1 25mm Sirius Plössl eyepiece
- 1 10mm Sirius Plössl eyepiece
- 1 9x50 Finder scope
- 1 Finder scope bracket with O-ring
- 1 Collimation cap
- 1 Camera adapter
- 1 Dust cover

## 3. Assembly

1. Stand the tripod legs upright and spread the legs out as far as they will go. Make certain that the leg lock levers are tightened. Assembly should take no more than 30 minutes. Refer to Figure 1 during assembly. Assembling the telescope requires no tools other than the ones provided.
2. Place the base of the equatorial mount onto the tripod head. Orient the equatorial mount so that the post on the tripod head lines up with the azimuth adjustment knobs on the equatorial mount (Figure 2). You may need to loosen

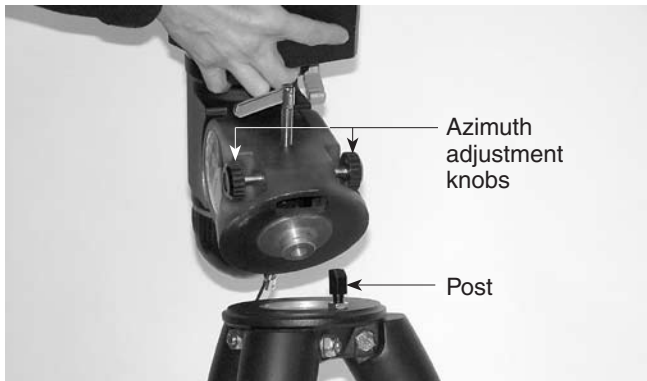

**Figure 2.** Orient the equatorial head so that the post on the tripod lines up with the azimuth adjustment knobs on the equatorial mount.

the azimuth adjustment knobs on the equatorial mount in order to fit the mount onto the tripod head.

3. Thread the central support shaft into the equatorial mount until tight. This will secure the equatorial mount to the tripod head.
4. Remove the knob and washer from the bottom of the center support shaft. Slide the tripod support tray up the bottom of the central support shaft until the three tray arms are touching the legs of the tripod. The flat side of the support tray should be facing up. Make sure the “V” of each tray arm is against a tripod leg. Place the knob washer on the center support shaft against the tray, and follow it by threading the securing knob all the way up the center support shaft until it is tight against the tray. The tripod support tray provides additional stability for the tripod, and holds up to five 1.25" eyepieces and two 2" eyepieces.
5. Loosen the counterweight shaft lock lever and let the counterweight shaft extend into its downward position. Retighten the lock lever.
6. Remove the knurled “toe saver” retaining screw on the bottom of the counterweight shaft and slide all three counterweights onto the shaft. Make sure the counterweight lock knobs are adequately loosened to allow the counterweight shaft to pass through the hole. Position the counterweights about halfway up the shaft and tighten the lock knobs. Replace the toe saver at the end of the bar. The toe saver prevents the counterweights from falling on your foot if the lock knobs happen to come loose.
7. Loosen and open the tube rings on the optical tube and remove the optical tube from the tube rings. Attach the tube rings to the mounting plate with the provided screws. Loosen the two mounting plate securing knobs. Place the mounting plate, with the tube rings attached, in the dovetail slot on top of the equatorial mount. Position the mounting plate so that it is centered on the dovetail slot. Re-tighten the mounting plate securing knobs until the mounting plate is secure.
8. Open the tube rings and lay the telescope optical tube in the rings at about the midpoint of the tube’s length. Rotate

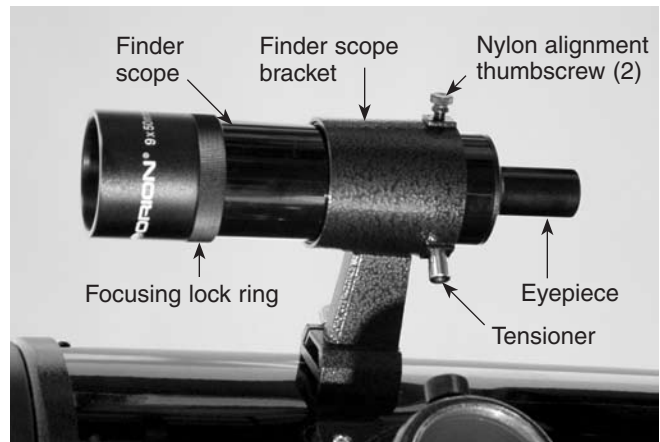

**Figure 3a.** The 9x50 finder scope and bracket.



**Figure 3b.** Pull back on the tensioner and slide the finder scope into its bracket until the O-ring is seated in the bracket ring.

the tube so that the focuser is at a convenient height for viewing. Close the tube rings and tighten them.

9. Insert the plug on the end of the control cable from the hand controller into its jack on the side of the equatorial mount.
10. Insert eight D-cell batteries into the battery pack. Orient the batteries as indicated on the white plastic battery holder. Plug the battery cord into its jack on the mount.
11. Two strips of nylon adhesive (one strip of “hooks” and one strip of “loops”) have been provided so you can create a place to keep the hand controller out of the way when not in use. Place the “hooks” strip of nylon adhesive on the back of the hand controller and the “loops” strip on a tripod leg or on the mount where it will be in a conveniently reached spot. Simply hang the hand controller by the nylon adhesive when it is not in use. Make certain when you attach the nylon adhesive to the mount that the hand controller’s position will not interfere with the motion of the mount.

### Installing the Finder Scope

To place the finder scope (Figure 3a) in the finder scope bracket, unthread the two black nylon thumbscrews until the screw ends are flush with the inside diameter of the bracket. Place

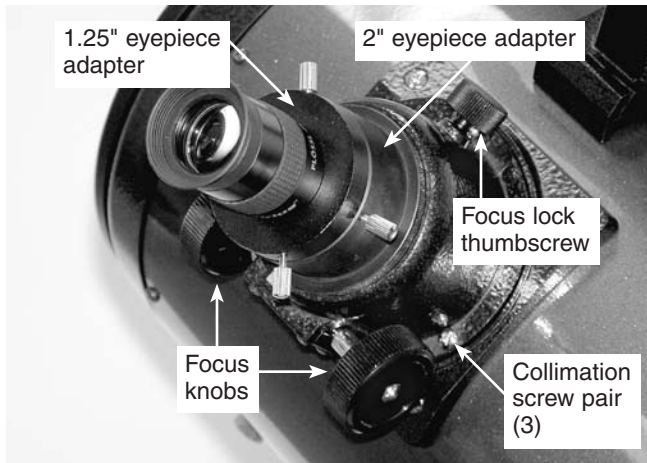

**Figure 4.** The 2" focuser of the Atlas 10 EQ.

the O-ring that comes on the base of the bracket over the body of the finder scope until it seats into the slot on the middle of the finder scope. Slide the eyepiece end (narrow end) of the finder scope into the end of the bracket's cylinder opposite the alignment screws while pulling the chrome, spring-loaded tensioner on the bracket with your fingers (Figure 3b). Push the finder scope through the bracket until the O-ring seats just inside the front opening of the bracket cylinder. Release the tensioner and tighten the two black nylon thumbscrews a couple of turns each to secure the finder scope in place. Insert the base of the finder scope bracket into the dovetail holder on the top of the focuser. Lock the bracket into position by tightening the knurled thumbscrew on the dovetail holder.

### Inserting the Eyepiece

Loosen the thumbscrew on the 1.25" adapter (Figure 4) and remove the small dust cap. Insert the 25mm eyepiece into the focuser and secure it with the thumbscrew.

Your Atlas 10 EQ is now fully assembled and should resemble Figure 1.

### Note about the Atlas 10 EQ Mount Weight

The Atlas 10 EQ mount is very heavy. Alone it weighs 54 lbs. With the optical tube and counterweights it weighs over 120 lbs. Keep this in mind when moving the telescope even small distances, and use assistance when needed. It is best to remove the optical tube and counterweights when moving the mount, or adjusting the length of the tripod legs.

## 4. Balancing the Telescope

To ensure smooth movement of the telescope on both axes of the equatorial mount, it is imperative that the optical tube is properly balanced. We will first balance the telescope with respect to the right ascension (R.A.) axis, then the declination (Dec.) axis.

1. Keeping one hand on the telescope optical tube, loosen the R.A. lock lever. Make sure the Dec. lock lever is locked, for now. The telescope should now be able to rotate freely

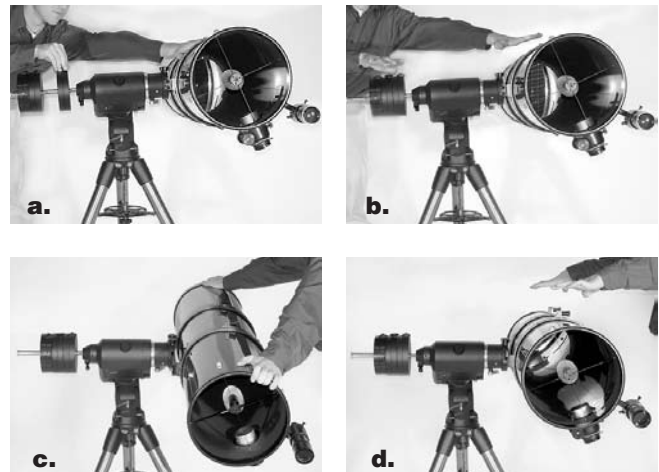

**Figure 5a-d.** Proper operation of the equatorial mount requires that the telescope tube be balanced on the R.A. and Dec. axes. (a) With the R.A. lock lever released, slide the counterweights down the counterweight shaft until they just counterbalance the telescope tube. (b) When you let go with both hands, the tube should not drift up or down (c) with the Dec. lock lever released, loosen the tube ring lock clamps a few turns and slide the telescope forward or back in the tube rings. (d) When the tube is balanced about the Dec. axis, it will not move when you let go.

- about the right ascension axis. Rotate it until the counterweight shaft is parallel to the ground (i.e., horizontal).
2. Now loosen the counterweight lock knobs and slide the weights along the shaft until they exactly counterbalance the telescope (Figure 5a). That's the point at which the shaft remains horizontal even when you let go with both hands (Figure 5b).
3. Retighten the counterweight lock knobs. The telescope is now balanced on the right ascension axis.
4. To balance the telescope on the declination axis, first tighten the R.A. lock lever, with the counterweight shaft still in the horizontal position.
5. With one hand on the telescope optical tube, loosen the Dec. lock lever. The telescope should now be able to rotate freely about the declination axis.
6. Loosen the knurled ring clamps on the tube rings a few turns, until you can slide the telescope tube forward and back inside the rings (this can be aided by using a slight twisting motion on the optical tube while you push or pull on it) (Figure 5c).
7. Position the telescope in the tube rings so it remains horizontal when you carefully let go with both hands. This is the balance point for the optical tube with respect to the Dec. axis (Figure 5d).
8. Retighten the knurled rings clamps.

The telescope is now balanced on both axes. When you loosen the lock lever on one or both axes and manually point the telescope, it should move without resistance and should not drift from where you point it.



Naked-eye view



View through finder scope and telescope

**Figure 6.** The view through a standard finder scope and reflector telescope is rotated 180°. This is true for the Atlas 10 EQ and its finder scope as well.

## 5. Using Your Telescope

### Focusing the Telescope

With the 25mm eyepiece inserted in the focuser, loosen the R.A. and Dec. lock levers and move the telescope so the front (open) end is pointing in the general direction of an object at least 1/4-mile away. Now, with your fingers, slowly rotate one of the focusing knobs until the object comes into sharp focus. Go a little bit beyond sharp focus until the image just starts to blur again, then reverse the rotation of the knob, just to make sure you've hit the exact focus point.

**NOTE: The image in the telescope will appear rotated 180° (upside down and reversed left-to-right). This is normal for astronomical scopes. The finder scope view will also be rotated 180° (see Figure 6).**

If you have trouble focusing, rotate the focusing knob so the drawtube is in as far as it will go. Now look through the eyepiece while slowly rotating the focusing knob in the opposite direction. You should soon see the point at which focus is reached.

The black nylon thumbscrew on the top of the body of the focuser (see Figure 4) will lock the focuser drawtube in place once the telescope is properly focused. Before focusing, remember to first loosen this thumbscrew.

### Viewing with Eyeglasses

If you wear eyeglasses, you may be able to keep them on while you observe, if the eyepiece has enough “eye relief” to allow you to see the whole field of view. You can try this by looking through the eyepiece first with your glasses on, and then with them off, and see if the glasses restrict the view to only a portion of the full field. If they do, you can easily observe with your glasses off by just re-focusing the telescope the needed amount. If you suffer from severe astigmatism, however, you may find images noticeably sharper with your glasses on.

### Aligning the Finder Scope

The Atlas 10 EQ Deluxe comes with a 9x50 achromatic finder scope (Figure 3a). The number 9 means six-times magnifica-

tion and the 50 indicates a 50mm diameter front lens. The finder scope makes it easier to locate the object you want to observe in the telescope, because the finder scope has a much wider field-of-view.

The Atlas 10 EQ's finder scope uses a spring-loaded bracket that makes alignment of the finderscope very easy. As you turn either of the thumbscrews, the spring in the bracket's tensioner moves in and out to keep the finder scope secure in the bracket.

The finder scope must be aligned accurately with the telescope for proper use. To align it, first aim the main telescope in the general direction of an object at least a 1/4 mile away—the top of a telephone pole, a chimney, etc. Loosen the R.A. and Dec. lock levers and move the telescope until it is pointing toward the desired object. Then sight along the tube to precisely aim the telescope. Turn the focus knob until the object is properly focused. Retighten the lock levers.

Now look in the finder scope. Is the object visible? Ideally it will be somewhere in the field of view. If not, some coarse adjustment to the finder scope bracket's alignment thumbscrews will be needed until the object comes into the finder scope's field of view.

With the image in the finder scope's field of view, you now need to fine-adjust the alignment thumbscrews to center the object on the intersection of the crosshairs. Adjust the aim of the finder scope by turning the thumbscrews, one at a time, until the object is centered.

The finder scope alignment needs to be checked before every observing session. This can easily be done at night, before viewing through the telescope. Choose any bright star or planet, center the object in telescope eyepiece, and then adjust the finder scope bracket's alignment thumbscrews until the star or planet is centered on the finder's crosshairs.

### Focusing the finder scope

If, when you look through the finder scope, the images appear somewhat out of focus, you will need to refocus the finder scope for your eyes. Loosen the lock ring located behind the objective lens cell on the body of the finder scope (see Figure 3a). Back the lock ring off by a few turns, for now. Refocus the finder scope on a distant object by threading the objective lens cell in or out of the finderscope body. Precise focusing will be achieved by focusing the finder scope on a bright star. Once the image appears sharp, retighten the locking ring behind the objective lens cell. The finder scope's focus should not need to be adjusted again.

### Magnification & Eyepieces

Magnification, or power, is determined by the focal length of the telescope and the focal length of the eyepiece. Therefore, by using eyepieces of different focal lengths, the resultant magnification can be varied.

Magnification is calculated as follows:

$$\frac{\text{Telescope Focal Length (mm)}}{\text{Eyepiece Focal Length (mm)}} = \text{Magnification}$$

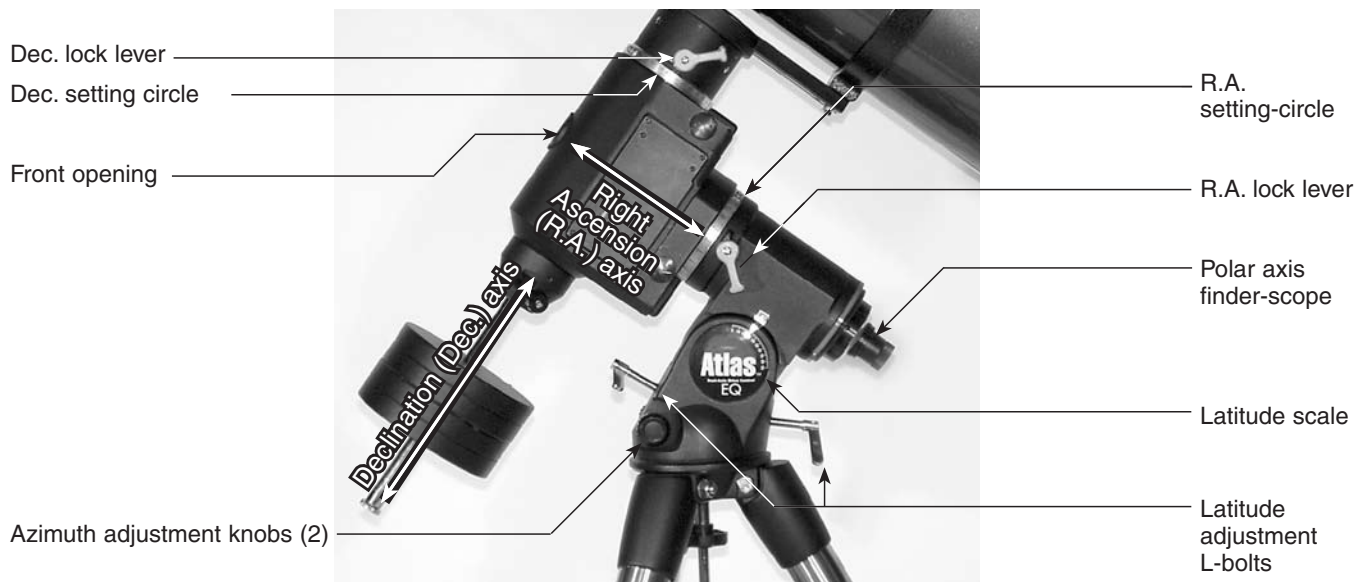

**Figure 7.** The Atlas EQ Mount.

The Atlas 10 EQ has a focal length of 1200mm, which when used with the supplied 25mm eyepiece yields a magnification of:

$$\frac{1200\text{mm}}{25\text{mm}} = 48\times$$

The magnification provided by the 10mm eyepiece is:

$$\frac{1200\text{mm}}{10\text{mm}} = 120\times$$

The maximum attainable magnification for a telescope is directly related to how much light it can gather. The larger the aperture, the more magnification is possible. In general a figure of 60x per inch of aperture is the maximum attainable for most telescopes. Your Atlas 10 EQ has an aperture of 10 inches, so the maximum magnification would be about 600x. This level of magnification assumes you have ideal conditions for viewing.

Keep in mind that as you increase magnification, the brightness of the object viewed will decrease; this is an inherent principle of the laws of physics and cannot be avoided. If magnification is doubled, an image appears four times dimmer. If magnification is tripled, image brightness is reduced by a factor of nine!

Always start with your lowest power eyepiece and work your way up. Start by centering the object being viewed in the 25mm eyepiece. Then you may want to increase the magnification to get a closer view. If the object is off-center (i.e., it is near the edge of the field of view) you will lose it when you increase magnification since the field of view will be narrower with the higher-powered eyepiece. To change eyepieces, first loosen the securing thumbscrew on the focuser's 1.25" adapter. Then carefully lift the eyepiece out of the holder. Do not tug or pull the eyepiece to the sides, as this will knock the telescope off its target. Replace the eyepiece with the new one by sliding it gently

into the holder. Re-tighten the thumbscrew, and refocus for your new magnification.

### Using 2" eyepieces

The Atlas 10 EQ's focuser is capable of accepting optional 2" eyepieces. To use 2" eyepieces you must remove the 1.25" adapter from the focuser by loosening the two thumbscrews that hold it in place (Figure 4). Once this adapter is removed, insert a 2" eyepiece into the focuser and use the same thumbscrews to secure the larger eyepiece. 2" eyepieces typically provide a wider field of view than 1.25" eyepieces.

## 6. Setting Up and Using the Equatorial Mount

When you look at the night sky, you no doubt have noticed that the stars appear to move slowly from east to west over time. That apparent motion is caused by the Earth's rotation (from west to east). An equatorial mount (Figure 7) is designed to compensate for that motion, allowing you to easily "track" the movement of astronomical objects, thereby keeping them from drifting out of your telescope's field of view while you're observing.

This is accomplished by slowly rotating the telescope on its right ascension (R.A.) axis, using the built in motor drive. But first the R.A. axis of the mount must be aligned with the Earth's rotational (polar) axis—a process called polar alignment.

### Polar Alignment

For Northern Hemisphere observers, approximate polar alignment is achieved by pointing the mount's right ascension axis at the North Star, or Polaris. It lies within 1° of the north celestial pole (NCP), which is an extension of the Earth's rotational

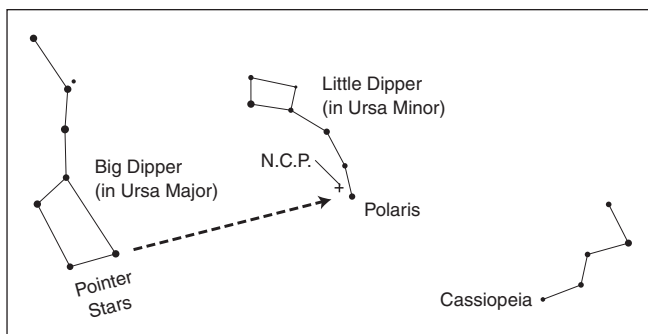

**Figure 8.** To find Polaris in the night sky, look north and find the Big Dipper. Extend an imaginary line from the two “Pointer Stars” in the bowl of the Big Dipper. Go about five times the distance between those stars and you’ll reach Polaris, which lies within 1° of the north celestial pole (NCP).

axis out into space. Stars in the Northern Hemisphere appear to revolve around the NCP.

To find Polaris in the sky, look north and locate the pattern of the Big Dipper (Figure 8). The two stars at the end of the “bowl” of the Big Dipper point right to Polaris.

Observers in the Southern Hemisphere aren’t so fortunate to have a bright star so near the south celestial pole (SCP). The star Sigma Octantis lies about 1° from the SCP, but it is barely visible with the naked eye (magnitude 5.5).

For general visual observation, an approximate polar alignment is sufficient.

1. Level the equatorial mount by adjusting the length of the three tripod legs. For your safety, remove the optical tube and counterweights when doing this.
2. There are two altitude adjusting L-bolts (see Figure 7); loosen one while tightening the other. By doing this you will adjust the latitude of the mount. Continue adjusting the mount until the pointer on the latitude scale is set at the latitude of your observing site. If you don’t know your latitude, consult a geographical atlas to find it. For example, if your latitude is 35° North, set the pointer to 35. The latitude setting should not have to be adjusted again unless you move to a different viewing location some distance away.
3. Loosen the Dec. lock lever and rotate the telescope’s optical tube until it is parallel with the right ascension axis, as it is in Figure 7.
4. Move the tripod so the telescope tube and right ascension axis point roughly at Polaris. If you cannot see Polaris directly from your observing site, consult a compass and rotate the tripod so the telescope points north.

The equatorial mount is now polar aligned for casual observing. More precise polar alignment is recommended for astrophotography. For this we recommend using the optional polar axis finder scope

From this point on in your observing session, you should not make any further adjustments to the latitude of the mount,

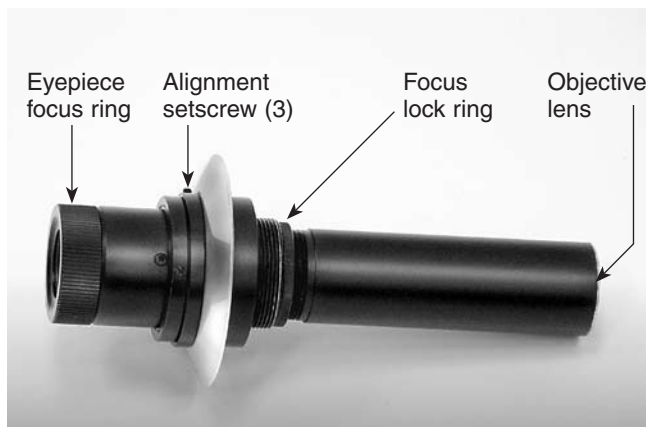

**Figure 9.** The optional polar axis finder scope.

nor should you move the tripod. Doing so will undo the polar alignment. The telescope should be moved only about its R.A. and Dec. axes.

### Using the Polar Axis Finder Scope

The Atlas EQ mount comes with a polar axis finder scope (Figure 9) housed inside the right ascension axis of the mount. When properly aligned and used, it makes accurate polar alignment quick and easy to do.

### Alignment of the Polar Axis Finder Scope

1. Loosen the Dec. lock lever and rotate the optical tube on the declination axis so that the tube is at a 90° to the right ascension axis (Figure 10). Tighten the Dec. lock lever.
2. Look through the polar finder at a distant object (during the day) and center it on the crosshairs. You may need to adjust the latitude adjustment L-bolts and the tripod position to do this.
3. Rotate the mount 180° about the R.A. axis. It may be convenient to remove the counterweights and optical tube first.
4. Look through the polar finder again. Is the object being viewed still centered on the crosshairs? If it is, then no further adjustment is necessary. If not, then look through the polar finder while rotating the mount about the R.A. axis. You will notice that the object you have previously centered moves in a circular path. Use the three alignment setscrews on the polar axis finder (Figure 9) to redirect the crosshairs of the polar finder to the apparent center of this circular path. Repeat this procedure until the position that the crosshairs point to does not rotate off-center when the mount is rotated in R.A.

The polar axis finder scope is now ready to be used. When not in use, replace the plastic protective cover to prevent the polar finder from getting bumped.

### Using the Polar Axis Finder Scope

The reticle of the polar axis finder scope for the Atlas has a tiny star map printed on it that makes precise polar alignment

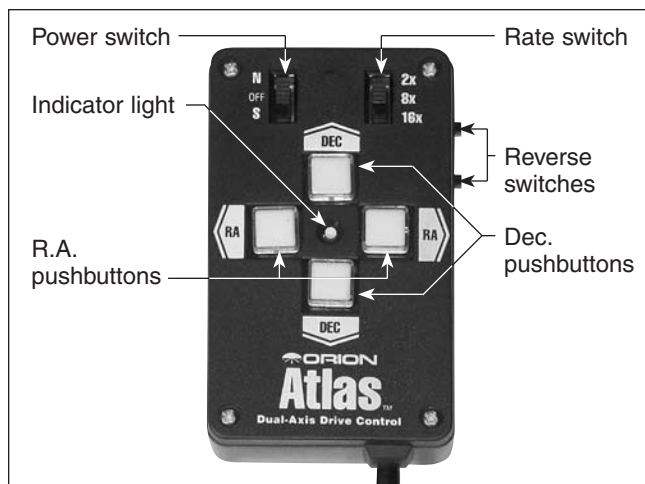



**Figure 10.** The optical tube must be at a 90° angle to the R.A. axis in order to view through the polar axis finder.

quick and easy. To align the mount using the polar axis finder scope, follow these instructions:

1. Approximately polar-align the mount as outlined in the previous alignment procedure.
2. Loosen the Dec. lock lever and rotate the optical tube on the declination axis so that the tube is at a 90° to the right ascension axis (Figure 10). Tighten the Dec. lock lever.
3. Remove the cap on the front opening of the equatorial mount (Figure 7). Focus the polar finder by rotating the eyepiece. Now, sight Polaris in the polar axis finder scope. If you have followed the approximate polar alignment procedure accurately, Polaris will probably be within the field of view. If not, move the tripod left-to-right, and adjust the latitude up-and down until Polaris is somewhere within the field of view of the polar axis finder scope.
4. Flip the power switch on the hand controller (Figure 11) to the N or S position. With the power on, you can now use the illuminator on the polar axis reticle. Look through the polar axis finder and adjust the illuminator by turning the small dial on the mount (located above the power and hand controller jacks) counter-clockwise to make it brighter, and clockwise to make it dimmer. Use the dimmest possible setting that allows you to see the reticle without difficulty. Note the constellation Cassiopeia and the Big Dipper in the reticle. They do not appear in scale, but they indicate the general positions of Cassiopeia and the Big Dipper relative to the north celestial pole (which is indicated by the cross at the center of the reticle). Rotate the reticle so the constellations depicted match their current orientation in they sky when viewed with the naked eye. To do this, release the R.A. lock lever and rotate the main telescope around the R.A. axis until the reticle is oriented with sky. You may need to remove the tube from the mount to prevent it from bumping into the mount. Once the reticle is correctly oriented, use the right ascension lock lever to secure the mount's position.
5. Now use the azimuth adjustment knobs (Figure 2) and the latitude adjustment L-bolts (Figure 7) on the mount to position the star Polaris inside the tiny circle marked



**Figure 11.** The Atlas EQ Mount hand controller.

“Polaris” on the finder’s reticle. You must first loosen the knob underneath the equatorial mount on the center support shaft to use the azimuth adjustment knobs. Once Polaris is properly positioned within the reticle, you are precisely polar aligned.

If you do not have a clear view of Polaris from your observing site, you will not be able to use the polar axis finder to precisely polar align the telescope.

From this point on in your observing session, you should not make any further adjustments in the azimuth or the latitude of the mount, nor should you move the tripod. Doing so will undo the polar alignment. The telescope should be moved only about its right ascension and declination axes.

#### **Additional Note Regarding Focusing the Polar Axis Finder Scope**

The polar axis finder scope is normally focused by simply rotating the eyepiece focus ring. However, if after adjusting the focus ring you find that the image of the reticle is sharp, but the stars are out of focus, then you must adjust the focus of the polar axis finder’s objective lens. To do this, first remove the polar axis finder from the mount. Look through the polar axis finder at a star (at night) or distant object at least 1/4 mile away (during daylight). Use the eyepiece focus ring to bring the reticle into sharp focus. Now, loosen the focus lock ring (Figure 9) and thread the entire objective end of the finder inwards or outwards until images appear sharp. Re-tighten the focus lock ring. Once the polar axis finder’s objective lens is focused, it should not need to be adjusted again.

#### **Operation of the Atlas Mount Motor Drives**

The Atlas EQ mount comes with dual built-in motor drives. These motor drives will be used to “track” objects in the night sky, as well as to make small adjustments when aiming the telescope. The motors are controlled from the hand controller (Figure 11). To start the drives, flip the power switch on the hand controller to “N” if you live in the northern hemisphere, or “S” if you live in the southern hemisphere. When you flip

the power switch, the power indicator light on the mount will glow red and the power indicator light on the hand controller will glow green. Your mount will now be moving at the sidereal rate, which is the same rate as the sky's apparent motion. If the mount is properly polar aligned, it is now "tracking" the motion of astronomical objects as the Earth rotates.

To move your telescope to a new object, loosen both the R.A. and Dec. lock levers and move the telescope until it is pointed in the general direction of the object you wish to view. Retighten the R.A. and Dec. lock levers. To center the object in the eyepiece's field of view, you will usually need to use the hand controller.

There are four pushbuttons on the hand controller. If no buttons are pushed, the R.A. motor will turn the R.A. axis at sidereal rate to track the motion of the night sky. The left and right buttons move the mount about its R.A. axis, and the up and down buttons move the mount about its Dec. axis. The rate of speed is determined by the rate switch at the top right of the hand controller. If the switch is at the 2x position, the mount will move at two times sidereal rate when the right hand button is pushed, which will cause objects to viewed in the eyepiece to move slowly eastward. If the left button is pushed, the drive will stop turning, which will cause objects in the eyepiece to move slowly westward. The top and bottom buttons will cause the telescope to move north and south in declination at the 2x speed. Similarly, if the switch is at the 8x or 16x position, the mount will move eight times or sixteen times sidereal rate when a button is pushed.

The 2x sidereal rate is the best setting for making guiding corrections during long-exposure astrophotography. The 8x and 16x rates are best for centering an object within the telescope's eyepiece.

Whenever any of the four buttons on the hand controller are pressed, the LED in the center of the controller will shine red; when the button is released, the LED will be green. Also, when the LED starts to blink at a constant rate, its time to change the batteries in the battery pack.

### Using the R.A. and Dec. Reversal Switches

On the side of the hand controller, there are two reversal switches, one for the R.A. axis, and one for the Dec. axis. When these switches are flipped to the "REV" setting, the function of the pushbuttons on the hand controller will be reversed. The reversal switches allow you to orient the pushbuttons to the direction of the apparent movement of a guide star in a guide scope for astrophotography.

### Understanding the Setting Circles

The setting circles on an equatorial mount (Figure 12) enable you to locate celestial objects by their "celestial coordinates". Every object resides in a specific location on the "celestial sphere". That location is denoted by two numbers: its right ascension (R.A.) and declination (Dec.). In the same way, every location on Earth can be described by its longitude and latitude. Right ascension is similar to longitude on Earth, and declination is similar to latitude. The R.A. and Dec. values for

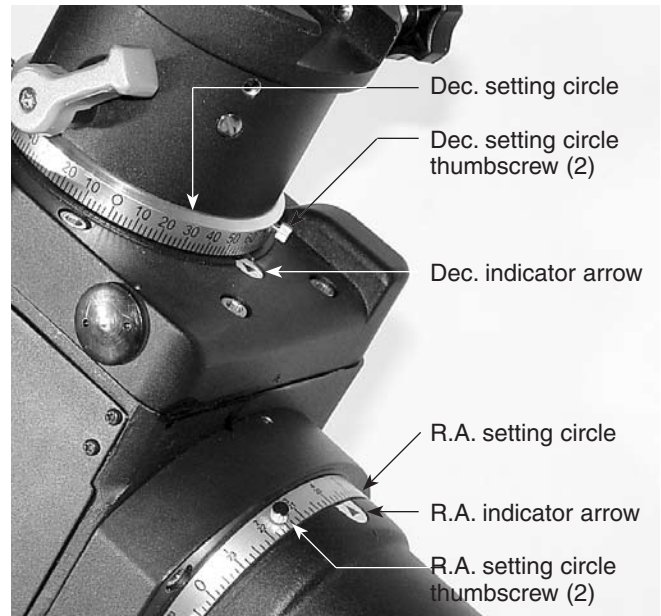

**Figure 12.** The R.A. and Dec. setting circles.

celestial objects can be found in any star atlas or star catalog.

The R.A. setting circle is scaled in hours, from 1 through 24, with small marks in between representing 10-minute increments (there are 60 minutes in 1 hour of right ascension). The lower set of numbers apply to viewing in the Northern Hemisphere, while the numbers above them apply to viewing in the Southern Hemisphere.

The Dec. setting circle is scaled in degrees, with each mark representing 2° increments. Values of declination coordinates range from +90° to -90°. The 0° mark indicates the celestial equator. When the telescope is pointed north of the celestial equator, values of the declination setting circle are positive; when the telescope is pointed south of the celestial equator, values of the declination setting circle are negative.

So, the coordinates for the Orion Nebula listed in a star atlas will look like this:

**R.A. 5h 35.4m Dec. – 5° 27'**

That's 5 hours and 35.4 minutes in right ascension, and –5 degrees and 27 arc-minutes in declination (there are 60 arc-minutes in 1 degree of declination).

Before you can use the setting circles to locate objects, the mount must be accurately polar aligned, and the setting circles must be calibrated.

### Calibrating the Declination Setting Circle

1. Loosen the Dec. lock lever and position the telescope as accurately as possible in declination so it is parallel to the R.A. axis as shown in Figure 7. Re-tighten the lock lever.
2. Loosen one of the thumbscrews on the Dec. setting circle, this will allow the setting circle to rotate freely. Rotate the

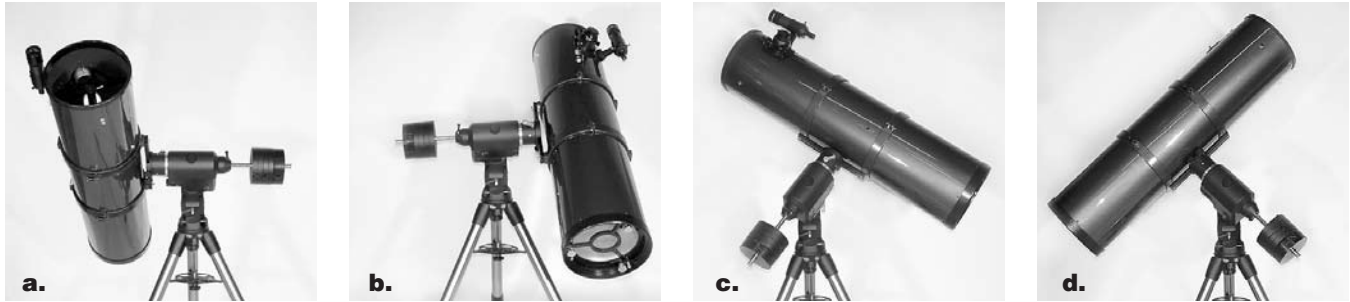

**Figure 13a-d.** These illustrations show the telescope pointed in the four cardinal directions. (a) north, (b) south, (c) east, (d) west. Note that the tripod and mount have not been moved; only the telescope has been moved on its R.A. and Dec. axes.

Dec. setting circle until the pointer reads exactly  $90^\circ$ . Retighten the setting circle thumbscrew.

### Calibrating the Right Ascension Setting Circle

1. Identify a bright star in the sky near the celestial equator (declination =  $0^\circ$ ) and look up its coordinates in a star atlas.
2. Loosen the R.A. and Dec. lock levers on the equatorial mount, so the telescope optical tube can move freely.
3. Point the telescope at the bright star whose coordinates you know. Lock the R.A. and Dec. lock levers. Center the star in the telescope's field of view with the hand controller.
4. Loosen one of the R.A. setting circle thumbscrews (see Figure 12) this will allow the setting circle to rotate freely. Rotate the setting circle until the R.A. pointer arrow indicates the R.A. coordinate listed in the star atlas for the object. Retighten the setting circle thumbscrew.

### Finding Objects With the Setting Circles

Now that both setting circles are calibrated, look up in a star atlas the coordinates of an object you wish to view.

1. Loosen the Dec. lock lever and rotate the telescope until the declination value from the star atlas matches the reading on the Dec. setting circle. Remember that values of the Dec. setting circle are positive when the telescope is pointing north of the celestial equator (Dec. =  $0^\circ$ ), and negative when the telescope is pointing south of the celestial equator. Retighten the lock lever.
2. Loosen the R.A. lock lever and rotate the telescope until the right ascension value from the star atlas matches the reading on the R.A. setting circle. Remember to use the lower set of numbers on the R.A. setting circle. Retighten the lock lever.

Most setting circles are not accurate enough to put an object dead-center in the telescope's eyepiece, but they should place the object somewhere within the field of view of the finder scope, assuming the equatorial mount is accurately polar aligned. Use the hand controller to center the object in the finder scope, and it should appear in the telescope's field of view.

The setting circles should be re-calibrated every time you wish to locate a new object. Do so by calibrating the setting circles for the centered object before moving on to the next one.

### Confused About Pointing the Telescope?

Beginners occasionally experience some confusion about how to point the telescope overhead or in other directions. In Figure 1 the telescope is pointed north as it would be during polar alignment. The counterweight shaft is oriented downward. But it will not look like that when the telescope is pointed in other directions. Let's say you want to view an object that is directly overhead, at the zenith. How do you do it?

DO NOT make any adjustment to the latitude adjustment L-bolts. That will spoil the mount's polar alignment. Remember, once the mount is polar aligned, the telescope should be moved only on the R.A. and Dec. axes. To point the scope overhead, first loosen the R.A. lock lever and rotate the telescope on the right ascension axis until the counterweight shaft is horizontal (parallel to the ground). Then loosen the Dec. lock lever and rotate the telescope until it is pointing straight overhead. The counterweight shaft is still horizontal. Then retighten both lock levers.

What if you need to aim the telescope directly north, but at an object that is nearer to the horizon than Polaris? You can't do it with the counterweights down as pictured in Figure 1. Again, you have to rotate the scope in right ascension so that the counterweight shaft is positioned horizontally. Then rotate the scope in declination so it points to where you want it near the horizon.

To point the telescope directly south, the counterweight shaft should again be horizontal. Then you simply rotate the scope on the declination axis until it points in the south direction.

To point the telescope to the east or west, or in other directions, you rotate the telescope on its right ascension and declination axes. Depending on the altitude of the object you want to observe, the counterweight shaft will be oriented somewhere between vertical and horizontal.

Figure 13 illustrates how the telescope will look when pointed at the four cardinal directions: north, south, east and west.

The key things to remember when pointing the telescope are that a) you only move it in right ascension and declination, not in azimuth or latitude (altitude), and b) the counterweight and

shaft will not always appear as it does in Figure 1. In fact it almost never will!

## 7. Collimating (Aligning The Mirrors)

Collimating is the process of adjusting the mirrors so they are aligned with one another. Your telescope's optics were aligned at the factory, and should not need much adjustment unless the telescope is handled roughly. Accurate mirror alignment is important to ensure the peak performance of your telescope, so it should be checked regularly. Collimating is relatively easy to do and can be done in daylight.

To check collimation, remove the eyepiece and look down the focuser drawtube. You should see the secondary mirror centered in the drawtube, as well as the reflection of the primary mirror centered in the secondary mirror, and the reflection of the secondary mirror (and your eye) centered in the reflection of the primary mirror, as in Figure 14a. If anything is off-center, as in Figure 14b, proceed with the following collimating procedure.

### Note About the 2" Focuser

The Atlas 10 EQ's 2" focuser can be collimated by 3 pairs of push-pull screws located on the ring at the base of the focuser (Figure 4). The focuser was collimated at the factory and should never need to be adjusted. Focuser collimating is only required under very rare circumstances but has been made available for this telescope should such a need arise.

### The Collimation Cap and Mirror Center Mark

Your Atlas 10 EQ comes with a collimation cap. This is a simple cap that fits on the focuser drawtube like a dust cap, but has a hole in the center and a silver bottom. This helps center your eye so that collimating is easy to perform. Figures 14b through 14e assume you have the collimation cap in place.

In addition to the collimation cap, the primary mirror is marked with a circle at its exact center. This "center mark" allows you to achieve a precise collimation of the primary mirror; you don't have to guess where the center of the mirror is. You simply adjust the mirror position (described below) until the reflection of the hole in the collimation cap is centered in the ring. The center mark is also required for best results when using other collimating devices, such as Orion's LaserMate Laser Collimator, obviating the need to remove the primary mirror and mark it yourself.

**Note: The center ring sticker need not ever be removed from the primary mirror. Because it lies directly in the shadow of the secondary mirror, its presence in no way adversely affects the optical performance of the telescope or the image quality. That might seem counter-intuitive, but its true!**

### Aligning the Secondary Mirror

With the collimation cap in place, look through the hole in the cap at the secondary (diagonal) mirror. Ignore the reflections

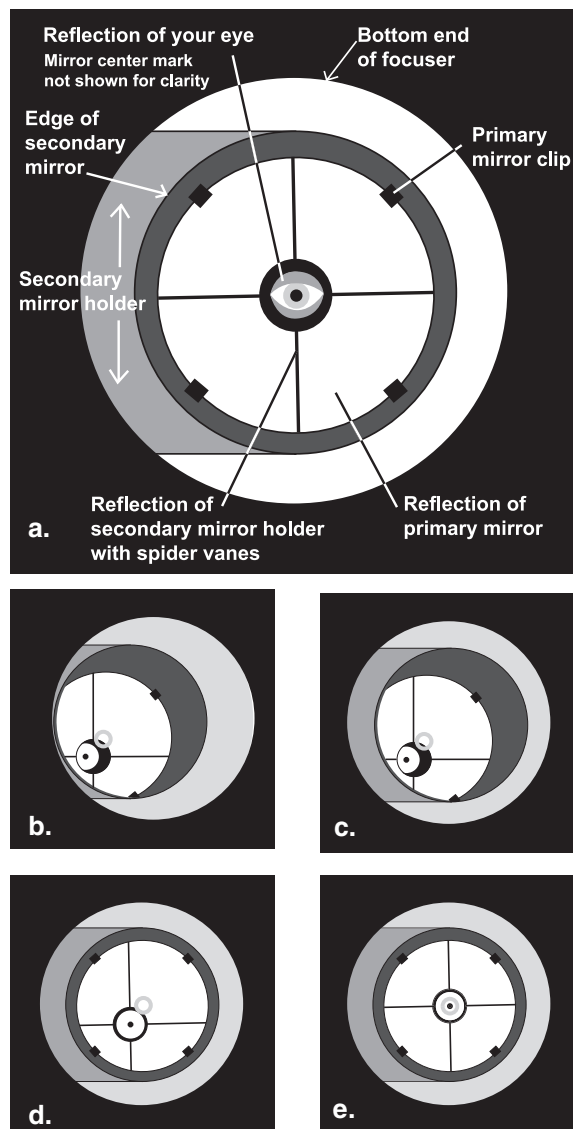

**Figure 14.** Collimating the optics. (a) When the mirrors are properly aligned, the view down the focuser drawtube should look like this (b) With the collimation cap in place, if the optics are out of alignment, the view might look something like this. (c) Here, the secondary mirror is centered under the focuser, but it needs to be adjusted (tilted) so that the entire primary mirror is visible. (d) The secondary mirror is correctly aligned, but the primary mirror still needs adjustment. When the primary mirror is correctly aligned, the "dot" will be centered, as in (e).

for the time being. The secondary mirror itself should be centered in the focuser drawtube, in the direction parallel to the length of the telescope. If isn't, as in Figure 14b, it must be adjusted. This adjustment will rarely, if ever need to be done.

It helps to adjust the secondary mirror in a brightly lit room with the telescope pointed towards a bright surface, such as white paper or wall. Also placing a piece of white paper in the telescope tube opposite the focuser (in other words, on the other side of the secondary mirror) will also be helpful in collimating the secondary mirror. Using a 2mm hex wrench,



**Figure 15.** To center the secondary mirror under the focuser, hold the secondary mirror holder in place with your fingers while adjusting the center screw with a Phillips screwdriver. Do not touch the mirror's surface!

**Figure 16.** Adjust the tilt of the secondary mirror by loosening or tightening the three alignment screws with a 2mm Allen wrench.

loosen the three small alignment set screws in the center hub of the 4-vaned spider several turns. Now keep the mirror's holder stationary (be careful not to touch the surface of the mirrors), while turning the center screw with a Phillips head screwdriver (See Figure 15). Turning the screw clockwise will move the secondary mirror toward the front opening of the optical tube, while turning the screw counter-clockwise will move the secondary mirror toward the primary mirror.

**Note:** When making these adjustments, be careful not to stress the spider vanes or they may bend.

When the secondary mirror is centered in the focuser draw-tube, rotate the secondary mirror holder until the reflection of the primary mirror is as centered in the secondary mirror as possible. It may not be perfectly centered, but that is OK. Now tighten the three small alignment screws equally to secure the secondary mirror in that position. This adjustment will rarely, if ever need to be done.

If the entire primary mirror reflection is not visible in the secondary mirror, as in Figure 14c; you will need to adjust the tilt of the secondary mirror. This is done by alternately loosening one of the three alignment set screws while tightening the other two, as depicted in Figure 16. The goal is to center the primary mirror reflection in the secondary mirror, as in Figure 14d. Don't worry that the reflection of the secondary mirror (the smallest circle, with the collimation cap "dot" in the center) is off-center. You will fix that in the next step.

### Adjusting the Primary Mirror

The final adjustment is made to the primary mirror. It will need adjustment if, as in Figure 14d, the secondary mirror is centered under the focuser and the reflection of the primary mirror is centered in the secondary mirror, but the small reflection of the secondary mirror (with the "dot" of the collimation cap) is off-center.

The tilt of the primary mirror is adjusted with three spring-loaded collimation thumbscrews on the back end of the optical tube (bottom of the primary mirror cell); these are the



**Figure 17.** The three thumb screws that lock the primary mirror in place must first be loosened before any adjustments can be made.



**Figure 18.** The tilt of the primary mirror is adjusted by turning one or more of the three spring-loaded collimation thumb screws.

larger thumbscrews. The other three smaller thumbscrews lock the mirror's position in place; these thumbscrews must be loosened before any collimation adjustments can be made to the primary mirror.

To start, turn the smaller thumbscrews that lock the primary mirror in place a few turns each. (Figure 17) Use a screwdriver in the slots, if necessary.

Now, try tightening or loosening one of the larger collimation thumbscrews with your fingers (Figure 18). Look into the focuser and see if the secondary mirror reflection has moved closer to the center of the primary. You can tell this easily with the collimation cap and mirror center mark by simply watching to see if the "dot" of the collimation cap is moving closer or further away from the "ring" on the center of the primary mirror mark. When you have the dot centered as much as is possible in the ring, your primary mirror is collimated. The view through the collimation cap should resemble Figure 15e. Re-tighten the locking thumbscrews.

A simple star test will tell you whether the optics are accurately collimated.

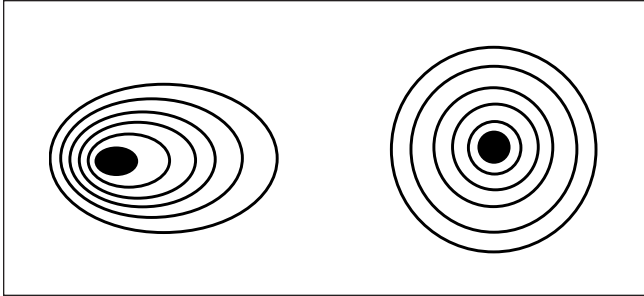

**Figure 19.** A star test will determine if a telescope's optics are properly collimated. An unfocused view of a bright star through the eyepiece should appear as illustrated on right if optics are perfectly collimated. If circle is unsymmetrical, as in illustration on left, scope needs collimation.

### Star-Testing the Telescope

When it is dark, point the telescope at a bright star and accurately center it in the eyepiece's field-of-view. Slowly defocus the image with the focusing knob. If the telescope is correctly collimated, the expanding disk should be a perfect circle (Figure 19). If the image is unsymmetrical, the scope is out of collimation. The dark shadow cast by the secondary mirror should appear in the very center of the out-of-focus circle, like the hole in a doughnut. If the "hole" appears off-center, the telescope is out of collimation.

If you try the star test and the bright star you have selected is not accurately centered in the eyepiece, then the optics will always appear out of collimation, even though they may be perfectly aligned. It is critical to keep the star centered, so over time you will need to make slight corrections to the telescope's position in order to account for the sky's apparent motion.

## 8. Astronomical Observing

For many users, the Atlas 10 EQ telescope will be a major leap into the world of amateur astronomy. This section is intended to get you ready for your voyages through the night sky.

### Observing Tips

#### A. Site Selection

Pick a location away from street lights and bright yard lighting. Avoid viewing over rooftops and chimneys, as they often have warm air currents rising from them, which distort the image seen in the eyepiece. Similarly, you should not observe through an open window from indoors. Better yet, choose a site out-of-town, away from any "light pollution". You'll be stunned at how many more stars you'll see! Most importantly, make sure that any chosen site has a clear view of a large portion of the sky.

#### B. Seeing and Transparency

Atmospheric conditions play a huge part in quality of viewing. In conditions of good "seeing", star twinkling is minimal and objects appear steady in the eyepiece. Seeing is best

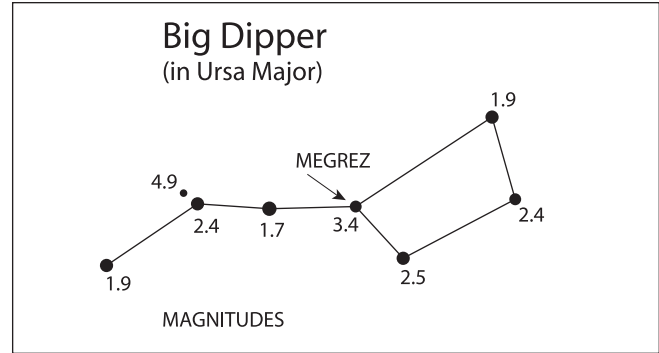

**Figure 20.** Megrez connects the Big Dipper's handle to its "pan". It is a good guide to how conditions are. If you can not see Megrez (a 3.4 mag star) then conditions are poor.

overhead, worst at the horizon. Also, seeing generally gets better after midnight, when much of the heat absorbed by the Earth during the day has radiated off into space. Typically, seeing conditions will be better at sites that have an altitude over about 3000 feet. Altitude helps because it decreases the amount of distortion causing atmosphere you are looking through.

A good way to judge if the seeing is good or not is to look at bright stars about 40° above the horizon. If the stars appear to "twinkle", the atmosphere is significantly distorting the incoming light, and views at high magnifications will not appear sharp. If the stars appear steady and do not twinkle, seeing conditions are probably good and higher magnifications will be possible. Also, seeing conditions are typically poor during the day. This is because the heat from the Sun warms the air and causes turbulence.

Good "transparency" is especially important for observing faint objects. It simply means the air is free of moisture, smoke, and dust. All tend to scatter light, which reduces an object's brightness.

One good way to tell if conditions are good is by how many stars you can see with your naked eye. If you cannot see stars of *magnitude* 3.5 or dimmer then conditions are poor. Magnitude is a measure of how bright a star is, the brighter a star is, the lower its magnitude will be. A good star to remember for this is Megrez (mag. 3.4), which is the star in the "Big Dipper" connecting the handle to the "dipper". If you cannot see Megrez, then you have fog, haze, clouds, smog, light pollution or other conditions that are hindering your viewing (See Figure 20).

#### C. Cooling the Telescope

All optical instruments need time to reach "thermal equilibrium" to achieve maximum stability of the lenses and mirrors, which is essential for peak performance. When moved from a warm indoor location outside to cooler air (or vice-versa), a telescope needs time to cool to the outdoor temperature. The bigger the instrument and the larger the temperature change, the more time will be needed. The Atlas 10 mirror is made of Pyrex, which is a low-expansion material used for superior thermal stability. The use of Pyrex reduces the amount of

---

cool-down time required for the Atlas 10, however, some cooling time will still be required for optimal viewing.

Allow at least 30 minutes for your Atlas 10 EQ to equilibrate. If the scope has more than a 40° temperature adjustment, allow an hour or more. In the winter, storing the telescope outdoors in a shed or garage greatly reduces the amount of time needed for the optics to stabilize. It also is a good idea to keep the scope covered until the Sun sets so the tube does not heat greatly above the temperature of the outside air.

You can attach a small fan to the Atlas 10 EQ to make cooling the tube faster. On the bottom of the mirror cell there are four holes (M4x.7 thread) where a fan can be mounted.

#### ***D. Let Your Eyes Dark-Adapt***

Do not expect to go from a lighted house into the darkness of the outdoors at night and immediately see faint nebulas, galaxies, and star clusters—or even very many stars, for that matter. Your eyes take about 30 minutes to reach perhaps 80% of their full dark-adapted sensitivity. Many observers notice improvements after several hours of total darkness. As your eyes become dark-adapted, more stars will glimmer into view and you will be able to see fainter details in objects you view in your telescope. Exposing your eyes to very bright daylight for extended periods of time can adversely affect your night vision for days. So give yourself at least a little while to get used to the dark before you begin observing.

To see what you are doing in the darkness, use a red-filtered flashlight rather than a white light. Red light does not spoil your eyes' dark adaptation like white light does. A flashlight with a red LED light is ideal, or you can cover the front of a regular incandescent flashlight with red cellophane or paper. Beware, too, that nearby porch and streetlights and automobile headlights will spoil your night vision.

#### **Eyepiece Selection**

By using eyepieces of varying focal lengths, it is possible to attain many magnifications with the Atlas 10 EQ. The telescope comes with two high-quality Sirius Plössl eyepieces: a 25mm, which gives a magnification of 48x, and a 10mm, which gives a magnification of 120x. Other eyepieces can be used to achieve higher or lower powers. It is quite common for an observer to own five or more eyepieces to access a wide range of magnifications. This allows the observer to choose the best eyepiece to use depending on the object being viewed. At least to begin with, the two supplied eyepieces will suffice nicely.

Whatever you choose to view, always start by inserting your lowest power (longest focal length) eyepiece to locate and center the object. Low magnification yields a wide field of view, which shows a larger area of sky in the eyepiece. This makes acquiring and centering an object much easier. If you try to find and center objects with high power (narrow field of view), it's like trying to find a needle in a haystack!

Once you've centered the object in the eyepiece, you can switch to higher magnification (shorter focal length eyepiece), if you wish. This is especially recommended for small and

bright objects, like planets and double stars. The Moon also takes higher magnifications well.

Deep-sky objects, however, typically look better at medium or low magnifications. This is because many of them are quite faint, yet have some extent (apparent width). Deep-sky objects will often disappear at higher magnifications, since greater magnification inherently yields dimmer images. This is not the case for all deep-sky objects, however. Many galaxies are quite small, yet are somewhat bright, so higher power may show more detail.

The best rule of thumb with eyepiece selection is to start with a low power, wide field, and then work your way up in magnification. If the object looks better, try an even higher magnification. If the object looks worse, then back off the magnification a little by using a lower power eyepiece.

#### **What to Expect**

So what will you see with your telescope? You should be able to see bands on Jupiter, the rings of Saturn, craters on the moon, the waxing and waning of Venus, and thousands of deep sky objects. Do not expect to see as much color as you in NASA photos, since those are taken with long-exposure cameras and have "false color" added. Our eyes are not sensitive enough to see color in deep-sky objects except in a few of the brightest ones.

Remember that you are seeing these objects using your own telescope with your own eyes! The object you see in your eyepiece is in real-time, and not some conveniently provided image from an expensive space probe. Each session with your telescope will be a learning experience. Each time you work with your telescope it will get easier to use, and stellar objects will become easier to find. Take it from us, there is big difference between looking at a well-made full-color NASA image of a deep-sky object in a lit room during the daytime, and seeing that same object in your telescope at night. One can merely be a pretty image someone gave to you. The other is an experience you will never forget!

#### **A. The Moon**

With its rocky and cratered surface, the moon is one of the most interesting and easy subjects for your scope. The best time to view it is during its partial phases when shadows fall on the craters and canyon walls to give its features definition. While the full moon may look like a tempting target, it is actually the worst time for viewing! The light of a full moon is too bright and lacks any decent surface definition.

Use an optional Moon filter to dim the Moon when it is very bright. It simply threads onto the bottom of the eyepiece from the focuser (you must first remove the eyepiece from the focuser to attach the filter). You'll find the Moon filter improves viewing comfort, and helps bring out the subtle features of the lunar surface.

#### **B. The Sun**

You can change your nighttime telescope into a daytime Sun viewer by installing an optional full-aperture solar filter over the front opening of a Atlas 10 EQ. The primary attraction is sunspots, which change shape, appearance, and location

daily. Sunspots are directly related to magnetic activity in the Sun. Many observers like to make drawings of sunspots to monitor how the Sun is changing from day to day.

**Important Note:** Do not look at the Sun with any optical instrument without a professionally made solar filter, or permanent eye damage could result. Also, be sure to cover the finder scope, or better yet, remove it altogether.

### C. The Planets

The planets don't stay put like the stars, so to find them you should refer to Sky Calendar at our website telescope.com, or to charts published monthly in *Astronomy*, *Sky & Telescope*, or other astronomy magazines. Venus, Mars, Jupiter, and Saturn are the brightest objects in the sky after the Sun and the Moon. Your Atlas 10 EQ is capable of showing you these planets in some detail. Other planets may be visible but will likely appear starlike. Because planets are quite small in apparent size, optional higher power eyepieces are recommended and often needed for detailed observations. Not all the planets are generally visible at any one time.

**JUPITER** The largest planet, Jupiter, is a great subject for observation. You can see the disk of the giant planet and watch the ever-changing positions of its four largest moons—Io, Callisto, Europa, and Ganymede. Higher power eyepieces should bring out the cloud bands on the planet's disk.

**SATURN** The ringed planet is a breathtaking sight when it is well positioned. The tilt angle of the rings varies over a period of many years; sometimes they are seen edge-on, while at other times they are broadside and look like giant "ears" on each side of Saturn's disk. A steady atmosphere (good seeing) is necessary for a good view. You will probably see a bright "star" close by, which is Saturn's brightest moon, Titan.

**VENUS** At its brightest, Venus is the most luminous object in the sky, excluding the Sun and the Moon. It is so bright that sometimes it is visible to the naked eye during full daylight! Ironically, Venus appears as a thin crescent, not a full disk, when at its peak brightness. Because it is so close to the Sun, it never wanders too far from the morning or evening horizon. No surface markings can be seen on Venus, which is always shrouded in dense clouds.

**MARS** The Red Planet makes its closest approach to Earth every two years. During close approaches you'll see a red disk, and may be able to see the polar ice cap. To see surface detail on Mars, you will need a high power eyepiece and very steady air!

### D. The Stars

Stars will appear like twinkling points of light. Even powerful telescopes cannot magnify stars to appear as more than a point of light! You can, however, enjoy the different colors of the stars and locate many pretty double and multiple stars. The famous "Double-Double" in the constellation Lyra and the gorgeous two-color double star Albireo in Cygnus are favorites. Defocusing a star slightly can help bring out its color.

### E. Deep-Sky Objects

Under dark skies, you can observe a wealth of fascinating deep-sky objects, including gaseous nebulas, open and glob-

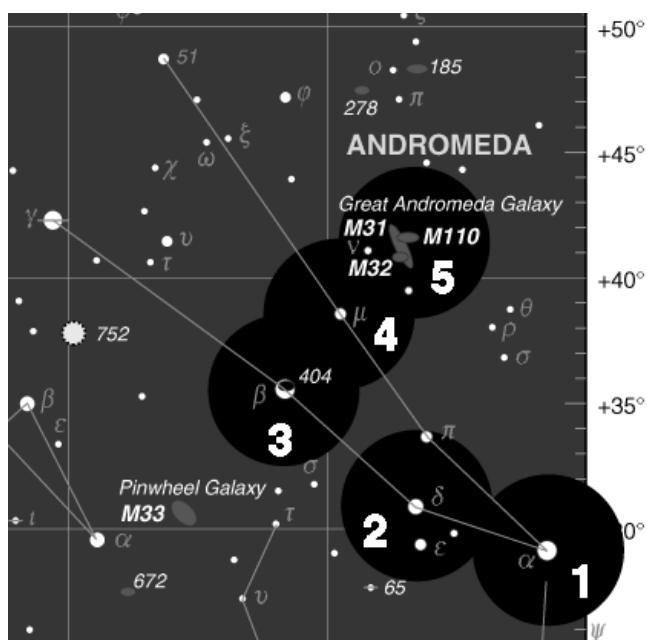

**Figure 21.** Starhopping is a good way to locate hard-to-find objects. Refer to a star chart to map a route to the object that uses bright stars as guideposts. Center the first star you've chosen in the finder scope and telescope eyepiece (1). Now move the scope carefully in the direction of the next bright star (2), until it is centered. Repeat (3 and 4). The last hop (5) should place the desired object in the eyepiece.

ular star clusters, and a variety of different types of galaxies. Most deep-sky objects are very faint, so it is important that you find an observing site well away from light pollution. Take plenty of time to let your eyes adjust to the darkness. Do not expect these subjects to appear like the photographs you see in books and magazines; many will look like dim gray smudges. But as you become more experienced and your observing skills get sharper, you will be able to ferret out more and more subtle details and structure.

### How to Find Deep-sky Objects: Starhopping

Starhopping, as it is called by astronomers, is perhaps the simplest way to hunt down objects to view in the night sky. It entails first pointing the telescope at a star close to the object you wish to observe, and then progressing to other stars closer and closer to the object until it is in the field of view of the eyepiece. It is a very intuitive technique that has been employed for hundreds of years by professional and amateur astronomers alike. Keep in mind, as with any new task, that starhopping may seem challenging at first, but will become easier over time and with practice.

To starhop, only a minimal amount of additional equipment is necessary. A star chart or atlas that shows stars to at least magnitude 5 is required. Select one that shows the positions of many deep-sky objects, so you will have a lot of options to choose from. If you do not know the positions of the constellations in the night sky, you will need to get a planisphere to identify them.





**Figure 22a.** First remove both the 1.25" and 2" adapters as shown.



**Figure 22b.** Thread the camera adapter into the focuser drawtube.



**Figure 22c.** The SkyView Pro 8 EQ with 35mm SLR camera attached.

Start by choosing bright objects to view. The brightness of an object is measured by its visual magnitude; the brighter an object, the lower its magnitude. Choose an object with a visual magnitude of 9 or lower. Many beginners start with the Messier objects, which represent some of the best and brightest deep-sky objects, first catalogued about 200 years ago by the French astronomer Charles Messier.

Determine in which constellation the object lies. Now, find the constellation in the sky. If you do not recognize the constellations on sight, consult a planisphere. The planisphere gives an all-sky view and shows which constellations are visible on a given night at a given time.

Now, look at your star chart and find the brightest star in the constellation that is near the object you are trying to find. Using the finder scope, point the telescope at this star and center it on the crosshairs. Next, look again at the star chart and find another suitably bright star near the bright star currently centered in the finder. Keep in mind that the field of view of the finder scope is approximately  $5^\circ$ , so you should choose another star that is no more than  $5^\circ$  from the first star, if possible. Move the telescope slightly, until the telescope is centered on the new star.

Continue using stars as guideposts in this way until you are at the approximate position of the object you are trying to find (Figure 21). Look in the telescope's eyepiece, and the object should be somewhere within the field of view. If it's not, sweep the telescope carefully around the immediate vicinity until the object is found.

If you have trouble finding the object, start the starhop again from the brightest star near the object you wish to view. This time, be sure the stars indicated on the star chart are in fact the stars you are centering in the eyepiece. Remember, the finder scope (and main telescope eyepiece, for that matter) gives an inverted image, so you must keep this in mind when starhopping from star to star.

## 9. Astrophotography

When coupled to a 35mm single-lens reflex camera, the Atlas 10 EQ becomes a telephoto lens. To attach a camera, you need only a T-ring for your specific camera model and the included camera adapter. First you must attach the includ-

ed camera adapter to the Atlas 10 EQ's focuser. To do this, remove the 1.25" and 2" eyepiece adapters from the focuser drawtube (Figure 22a). Then screw the camera adapter into the focuser drawtube (Figure 22b). Now attach the T-Ring to your camera and thread it onto the camera adapter (Figure 22c).

Use the camera's viewfinder to frame the picture. Use the telescope's focuser to focus the image. You may want to consider using a remote shutter release instead of the shutter release on the camera; touching the camera can vibrate the system and blur the resulting photographic image on the film. Use the focus lock knob on the focuser to fix the focus when the image is sharp.

Several different types of astrophotography can be successfully attempted with the Atlas 10 EQ.

### Moon Photography

This is perhaps the simplest form of astrophotography. Point the telescope toward the Moon, and center it within the camera's viewfinder. Focus the image with the telescope's focuser. Try several exposure times, all less than 1 second, depending on the phase of the moon and the ISO (film speed) of the film being used. A remote shutter release is recommended, as touching the camera's shutter release can vibrate the camera enough to ruin the exposure.

### Planetary Photography

Once basic Moon photography has been mastered, it's time to get images of the planets. This type of astrophotography also works to get highly magnified shots of the Moon. In addition to the T-ring, you will need a Universal 1.25" Camera Adapter. The equatorial mount must be accurately polar aligned, too.

As before, connect the T-ring to your camera. Before connecting the universal camera adapter to the T-ring, an eyepiece must be inserted and locked into the body of the universal camera adapter. Start by using a medium-low power eyepiece (about 25mm); you can increase the magnification later with a high-power eyepiece. Then connect the entire camera adapter, with eyepiece inside, to the T-Ring. Insert the whole system into the focuser's 1.25" adapter and secure firmly with the thumbscrew.

Aim the telescope at the planet (or Moon) you wish to shoot. The image will be highly magnified, so you may need to use

---

the finder scope to center it within the camera's viewfinder. Turn the motor drive on. Adjust the telescope's focuser so that the image appears sharp in the camera's viewfinder. The camera's shutter is now ready to be opened. A remote shutter release must be used or the image will be blurred beyond recognition. Try exposure times between 1 and 10 seconds, depending upon the brightness of the planet to be photographed and the ISO of the film being used.

### **“Piggyback Photography”**

The Moon and planets are interesting targets for the budding astrophotographer, but what next? Literally thousands of deep-sky objects can be captured on film with a type of astrophotography called “piggybacking”. The basic idea is that the camera with its own camera lens attached rides on top of the main telescope. The telescope and camera both move with the rotation of the Earth when the mount is polar aligned and the motor drive is engaged. This allows for a long exposure through the camera without having the object or background stars blurred. An illuminated reticle eyepiece will also be needed. The T-ring and camera adapter are not needed, since the camera is exposing through its own lens. Any camera lens with a focal length between 35mm and 400mm is appropriate.

On the top of one of the tube rings is a piggyback camera adapter. This is the black knob with the threaded shaft protruding through it. The tube ring with the piggyback adapter should be closest to the open end of the telescope tube. Remove the tube rings from the equatorial mount and swap their position if necessary. Now, connect the camera to the piggyback adapter. There should be a 1/4"-20 mounting hole in the bottom of the camera's body. Thread the protruding shaft of the piggyback adapter into the 1/4"-20 mounting hole in the camera a few turns. Position the camera so it is parallel with the telescope tube and turn the knurled black knob of the piggyback adapter counter-clockwise until the camera is locked into position.

Aim the telescope at a deep-sky object. It should be a fairly large deep-sky object, as the camera lens will likely have a wide field of view. Check to make sure that the object is also centered in the camera's viewfinder. Turn the motor drive on. Now, look into the telescope's eyepiece and center the brightest star within the field of view. Remove the eyepiece and insert the illuminated reticle eyepiece into the focuser drawtube. Turn the eyepiece's illuminator on (dimly!). Recenter the bright star (guide star) on the crosshairs of the reticle eyepiece. Check again to make sure that the object to be photographed is still centered within the camera's field of view. If it is not, recenter it by repositioning the camera on the piggyback adapter, or by moving the main telescope. If you move the main telescope, then you will need to recenter another guide star on the illuminated eyepiece's crosshairs. Once the object is centered in the camera and a guide star is centered in the reticle eyepiece, you're ready to shoot.

Deep-sky objects are quite faint, and typically require exposures on the order of 10 minutes. To hold the camera's shutter open this long, you will need a lock shutter release cable. Set the camera's shutter to the “B” (bulb) setting. Depress the

locking shutter release cable and lock it. You are now exposing your first deep-sky object.

While exposing through the camera lens, you will need to monitor the accuracy of the mount's tracking by looking through the illuminated reticle eyepiece in the main telescope. If the guide star drifts from its initial position, then use the hand controller (at the 2x rate) to “move” the guide star back to the center of the crosshairs. Any drifting along the Dec. axis is a result of improper polar alignment, so if the guide star drifts greatly in declination, the mount may need to be polar aligned more accurately.

When the exposure is complete, unlock the shutter release cable and close the camera's shutter.

Astrophotography can be enjoyable and rewarding, as well as frustrating and time-consuming. Start slowly and consult outside resources, such as books and magazines, for more details about astrophotography. Remember ... have fun!

## **10. Care and Maintenance**

If you give your telescope reasonable care, it will last a lifetime. Store it in a clean, dry, dust-free place, safe from rapid changes in temperature and humidity. Do not store the telescope outdoors, although storage in a garage or shed is OK. Small components like eyepieces and other accessories should be kept in a protective box or storage case. Keep the dust cover on the front of the telescope when not in use.

Your Atlas 10 EQ requires very little mechanical maintenance. The optical tube is steel and has a smooth painted finish that is fairly scratch-resistant. If a scratch does appear on the tube, it will not harm the telescope. Smudges on the tube can be wiped off with a soft cloth and a household cleaner such as Windex or Formula 409.

### **Cleaning Lenses**

Any quality optical lens cleaning tissue and optical lens cleaning fluid specifically designed for multi-coated optics can be used to clean the exposed lenses of your eyepieces or finder scope. Never use regular glass cleaner or cleaning fluid designed for eyeglasses. Before cleaning with fluid and tissue, however, blow any loose particles off the lens with a blower bulb or compressed air. Then apply some cleaning fluid to a tissue, never directly on the optics. Wipe the lens gently in a circular motion, then remove any excess fluid with a fresh lens tissue. Oily fingerprints and smudges may be removed using this method. Use caution; rubbing too hard may scratch the lens. On larger lenses, clean only a small area at a time, using a fresh lens tissue on each area. Never reuse tissues.

### **Cleaning Mirrors**

You should not have to clean the telescope's mirrors very often; normally once every year or so. Covering the telescope with the dust cover when it is not in use will prevent dust from accumulating on the mirrors. Improper cleaning can scratch mirror coatings, so the fewer times you have to clean the mirrors, the better. Small specks of dust or flecks of paint have virtually no effect on the visual performance of the telescope.

---

The large primary mirror and the elliptical secondary mirror of your telescope are front-surface aluminized and over-coated with hard silicon dioxide, which prevents the aluminum from oxidizing. These coatings normally last through many years of use before requiring re-coating (which is easily done).

To clean the secondary mirror, first remove it from the telescope. Do this by holding the secondary mirror holder stationary while turning the center Phillips-head screw. Be careful, there is a spring between the secondary mirror holder and the Phillips-head screw; be sure that it will not fall into the optical tube and hit the primary mirror. Handle the mirror by its holder; do not touch the mirror surface. Then follow the same procedure described below for cleaning the primary mirror. You do not need to remove the secondary mirror from its holder when cleaning.

To clean the primary mirror, carefully remove the mirror cell from the telescope. To do this means you must remove the six screws on the side of the tube near the primary mirror. You do not need to remove the collimation screws on the bottom of the mirror cell. Remove the mirror cell from the tube. You will notice the primary mirror is held down with four clips held by two screws each. Loosen the screws and remove the clips.

You may now remove the mirror from the mirror cell. Do not touch the surface of the mirror with your fingers. Lift the mirror carefully by the edges. Set the mirror on a clean soft towel. Fill a clean sink free of abrasive cleanser, with room-temperature water, a few drops of liquid dishwashing detergent, and if possible, a capful of rubbing alcohol. Submerge the mirror (aluminized face up) in the water and let it soak for a few minutes (or hours if it's a very dirty mirror). Wipe the mirror under water with clean cotton balls, using extremely light pressure and stroking in straight line across the mirror. Use one ball for each wipe across the mirror. Then rinse the mirror under a stream of lukewarm water. Any particles on the surface can be swabbed gently with a series of cotton balls, each used just one time. Dry the mirror in a stream of air (a "blower bulb" works great), or remove any stray drops of water with the corner of a paper towel. Water will run off a clean surface. Cover the mirror surface with Kleenex, and leave the mirror in a warm area until it is completely dry before reassembling the telescope.

## 11. Specifications

Primary mirror diameter: 254mm

Primary mirror coating: Aluminized, SiO<sub>2</sub> overcoat

Primary mirror material: Pyrex®

Focal length: 1200mm

Focal ratio: f/4.7

Secondary mirror axis: 64mm

Secondary mirror holder: Four-vaned spider

Eyepiece: 25mm and 10mm Sirius Plössls, fully coated, 1.25"

Magnification: 48x (with 25mm) and 120x (10mm)

Finder scope: 9x50 achromatic, 5° field of view

Focuser: Rack and pinion, push-pull tilt adjustment for collimating, accepts 2" and 1.25" eyepieces

Camera adapter: couples 35mm SLR camera T-Ring to focuser

Mount: Atlas, German equatorial

Tripod: Steel

Tripod support tray: Aluminum, provides additional stability, holds five 1.25" eyepieces and two 2" eyepieces

Weight: 54 lbs.

Counterweights: Quantity 3, 11 lbs. each

Setting circles: R.A. scaled in 10 min. increments, Dec. scaled in 2° increments for N or S hemisphere

Polar axis latitude adjustment: 10° to 65°

Polar axis finder scope: Included

Motor drives: Dual-axis, internally housed

Power requirements: 12V DC, tip positive

Battery type: Eight D-cells

Operation: Northern or Southern hemisphere

Guiding rates: Sidereal ±100% sidereal

Centering rates: ±8x sidereal, ±16x sidereal

---

## **One-Year Limited Warranty**

This Orion Atlas 10 EQ is warranted against defects in materials or workmanship for a period of one year from the date of purchase. This warranty is for the benefit of the original retail purchaser only. During this warranty period Orion Telescopes & Binoculars will repair or replace, at Orion's option, any warranted instrument that proves to be defective, provided it is returned postage paid to: Orion Warranty Repair, 89 Hangar Way, Watsonville, CA 95076. If the product is not registered, proof of purchase (such as a copy of the original invoice) is required.

This warranty does not apply if, in Orion's judgment, the instrument has been abused, mishandled, or modified, nor does it apply to normal wear and tear. This warranty gives you specific legal rights, and you may also have other rights, which vary from state to state. For further warranty service information, contact: Customer Service Department, Orion Telescopes & Binoculars, 89 Hangar Way, Watsonville, CA 95076; (800) 676-1343.

### **Orion Telescopes & Binoculars**

**89 Hangar Way, Watsonville, CA 95076**

**Customer Support Help Line (800) 676-1343 • Day or Evening**